

EMF AND ELECTRIC CIRCUITS

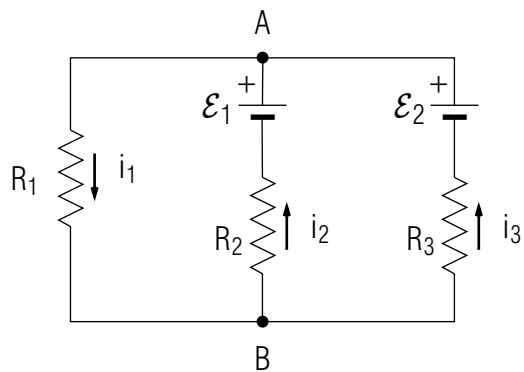

EMF AND ELECTRIC CIRCUITS

by
F. Reif, G. Brackett and J. Larkin

CONTENTS

- A. Emf Sources
- B. Circuit Analysis
- C. Power and Energy Transformations
- D. Alternating Currents
- E. Summary
- F. Problems

Title: **EMF and Electric Circuits**

Author: F. Reif and J. Larkin, Dept. of Physics, Univ. of Calif., Berkeley.

Version: 4/30/2002

Evaluation: Stage 0

Length: 1 hr; 60 pages

Input Skills:

1. Vocabulary: emf (MISN-0-423).
2. State Ohm's law for a resistor (MISN-0-424).

Output Skills (Knowledge):

- K1. Vocabulary: alternating current, ideal emf source.
- K2. State Thevenin's theorem for an equivalent two-terminal system.
- K3. Define the coulomb power and the non-coulomb power delivered to a two-terminal system.
- K4. For charged particles moving in a steady state, relate the power delivered to the particles (by coulomb and non-coulomb work) to the power dissipated by these particles into random internal energy.

Output Skills (Rule Application):

- R1. Given the emf of an ideal emf source, determine the potential difference encountered by a current which traverses the emf source.
- R2. Calculate the potential drop across a two-terminal system, given its resistance, emf, and the current through it, or given its equivalent circuit diagram.
- R3. Calculate the power delivered to or dissipated from a two-terminal system, given the appropriate values for current, potential drop, emf, and resistance.

Output Skills (Problem Solving):

- S1. Given some of the currents, potential differences, resistances, and emfs in a circuit, determine the unknown currents, potential differences, resistances, and emfs in the circuit by systematically applying the principles of circuit analysis and Ohm's law.

THIS IS A DEVELOPMENTAL-STAGE PUBLICATION
OF PROJECT PHYSNET

The goal of our project is to assist a network of educators and scientists in transferring physics from one person to another. We support manuscript processing and distribution, along with communication and information systems. We also work with employers to identify basic scientific skills as well as physics topics that are needed in science and technology. A number of our publications are aimed at assisting users in acquiring such skills.

Our publications are designed: (i) to be updated quickly in response to field tests and new scientific developments; (ii) to be used in both classroom and professional settings; (iii) to show the prerequisite dependencies existing among the various chunks of physics knowledge and skill, as a guide both to mental organization and to use of the materials; and (iv) to be adapted quickly to specific user needs ranging from single-skill instruction to complete custom textbooks.

New authors, reviewers and field testers are welcome.

PROJECT STAFF

Andrew Schnepf	Webmaster
Eugene Kales	Graphics
Peter Signell	Project Director

ADVISORY COMMITTEE

D. Alan Bromley	Yale University
E. Leonard Jossem	The Ohio State University
A. A. Strassenburg	S. U. N. Y., Stony Brook

Views expressed in a module are those of the module author(s) and are not necessarily those of other project participants.

© 2002, Peter Signell for Project PHYSNET, Physics-Astronomy Bldg., Mich. State Univ., E. Lansing, MI 48824; (517) 355-3784. For our liberal use policies see:

<http://www.physnet.org/home/modules/license.html>.

MISN-0-425

EMF AND ELECTRIC CIRCUITS

- A. Emf Sources
- B. Circuit Analysis
- C. Power and Energy Transformations
- D. Alternating Currents
- E. Summary
- F. Problems

Abstract:

We shall now apply the general principles of Unit 423 to examine two-terminal systems (such as batteries) which are more complex than resistors. We shall then be able to discuss practical circuits which consist ordinarily of both resistors and batteries. Finally, we shall study the energy conversion processes in such circuits and shall point out how energy can be transmitted in electric form.

SECT.

A EMF SOURCES

► Definition

An “emf source” is any two-terminal system having a non-zero emf (i.e., any two-terminal system in which non-coulomb work is done on moving charged particles).

► Examples

Figure A-1 illustrates two kinds of emf sources in which non-coulomb work is done to move charged particles against opposing coulomb forces. For example, in the Van de Graaf generator of Fig. A-1a, mechanical work is done on the charged particles on the conveyor belt to move these particles to the sphere against the opposing coulomb forces exerted on these particles by the charge accumulated on the sphere. Similarly, in the case of the battery illustrated in Fig. A-1b, chemical work is done (i.e., chemical energy is supplied by chemical reactions in the ionic solution) to move charged particles from one terminal of the battery to the other against the opposing coulomb forces exerted by the charges on these terminals.

Relation between I and V Consider any emf source, such as that indicated in Fig. A-2. According to Relation (F-4) of Unit 423, the steady current I flowing through such an emf source from terminal a to terminal b is related to the potential drop $V = V_{ab}$ from a to b by the relation

$$\boxed{RI = V + \mathcal{E}} \quad (\text{A-1})$$

where R is the resistance of the source and \mathcal{E} is its emf from a to b . (By definition, this emf is the non-coulomb work per unit charge done on a particle moving through the source from a to b .) By Def. (A-1), the potential drop across the source is then

$$V = -\mathcal{E} + RI \quad (\text{A-2})$$

Let us now look at various special cases.

► $I = 0$

If the steady current I through the emf source is zero (e.g., if the source is not connected to any other system), Def. (A-2) implies that:

$$V = -\mathcal{E}. \quad (\text{A-3})$$

Thus the *magnitude* of the potential drop across the source is then simply equal to the *magnitude* of the emf of the source. Furthermore, if the emf

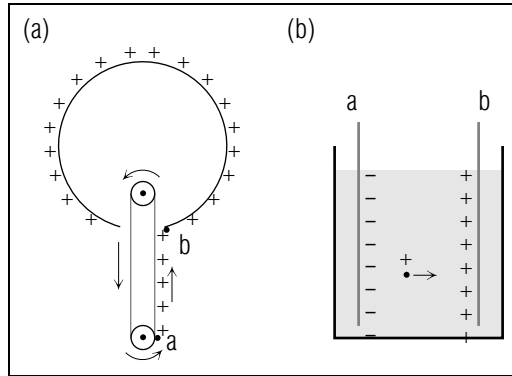

Fig. A-1: Emf sources in which non-coulomb work is done on charged particles to move these against opposing coulomb forces. (a) Van-de-Graaff generator. (b) Battery.

\mathcal{E} from a to b is positive, the potential drop $V = V_a - V_b$ from a to b is negative, i.e., the potential at b is larger than that at a .

This result makes physical sense. When no current flows through the emf source, no energy is dissipated into random internal energy of the source. Hence the non-coulomb energy supplied, per unit charge, to move a charged particle inside the source from a to b is just equal to the increase $V_b - V_a$ in the coulomb potential energy, per unit charge, of the particle. Accordingly, potential at terminal b is larger than that at a .

► $I \neq 0$

When a current I flows through the emf source, Def. (A-2) indicates that the magnitude $|V|$ of the potential drop across the source is *different* from the magnitude $|\mathcal{E}|$ of the emf. (The reason is that the non-coulomb energy supplied to a particle in the source is then no longer completely converted into coulomb potential energy, but is partly dissipated into random internal energy.) Furthermore, Def. (A-2) shows that the difference between $|V|$ and $|\mathcal{E}|$ is larger if the current I through the source is larger and if the resistance R of the source is larger.

Note that the non-coulomb work done on charged particles inside an emf source can make these particles move in a direction *opposite* to

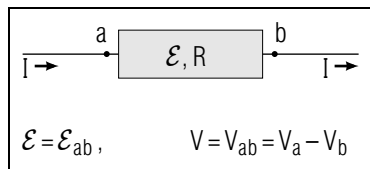

Fig. A-2: An emf source.

the electric force exerted on these particles by the electric field inside the source.

APPLICATION TO MEASUREMENT OF CHEMICAL ENERGIES

Suppose that a chemical reaction can be used to separate charged particles and thus to create a potential difference between two “electrodes” (i.e., between two rods immersed in the solution in which the reaction takes place). The potential difference between these electrodes, measured under conditions where no steady current flows, should then have a magnitude equal to the emf, i.e., equal to the chemical energy supplied per unit charge in the chemical reaction. In this way it is possible to measure chemical energies by simply measuring potential differences. Such electrical measurements of chemical energies are frequently used in chemistry since they are much simpler and more precise than the measurements of chemical energies obtained by measuring “heats of reaction.”

IDEAL EMF SOURCE

► *Definition*

A particularly simple case arises if the resistance R of an emf source is negligibly small. We shall call such a source “ideal.” Such an ideal source of emf is represented in a circuit diagram by the symbol shown in Fig. A-3. *

* The two lines in this symbol are supposed to be reminiscent of a simple battery consisting of two different metal plates immersed in ionic solution.

By convention, the emf \mathcal{E} written next to the circuit symbol is positive and denotes the emf \mathcal{E}_{-+} through the source from the terminal indicated by the $-$ sign (or the smaller line) to the terminal indicated by the $+$ sign (or the larger line).

Since $R = 0$ for an ideal emf source, Def. (A-2) implies that, *irrespective* of the current I through the source, the potential drop $V = V_{-+}$ from the $-$ to the $+$ terminal is always

$$\text{for ideal source, } V_{-+} = -\mathcal{E} \quad (\text{A-5})$$

(In other words, since $R = 0$ the dissipation of energy in an ideal emf source is always negligible. Hence the non-coulomb energy supplied to a

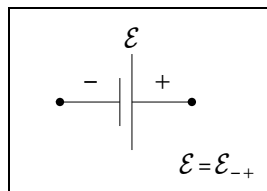

Fig. A-3: Symbol representing an ideal emf source.

charged particle in the source is always entirely converted into coulomb potential energy.)

According to Def. (A-5), the *magnitude* of the potential drop across an ideal source of emf is always equal to the *magnitude* of the emf of this source. Furthermore, the potential drop V_{-+} from the $-$ to the $+$ terminal is negative (i.e., opposite to the positive emf from the $-$ to the $+$ terminal). Correspondingly, the potential drop V_{+-} in the opposite direction has the opposite sign and is thus positive. In other words, $V_{+-} = -V_{-+}$ and Def. (A-5) is equivalent to the result:

$$\boxed{\text{for ideal source, } V_{+-} = \mathcal{E}} \quad (\text{A-6})$$

Since $V_{+-} = V_+ - V_-$ is positive, the potential V_+ at the $+$ terminal of the source is thus always larger than the potential V_- at the $-$ terminal of the source.

► *The Emf of a Source; a Flashlight Battery*

The *emf of a source* is, by convention, defined to be its \mathcal{E}_{-+} , the energy necessary to push a unit charge *through* the source from its $-$ terminal to its $+$ terminal. For example, the emf of a flashlight battery is 1.5 V: $\mathcal{E}_{\text{battery}} \equiv \mathcal{E}_{-+} = 1.5 \text{ V}$. For the moment we will assume that the battery is an ideal emf source so it has negligible internal resistance. Then it takes 1.5 joules of energy to push one coulomb of positive charge *through* the battery from its $-$ terminal to its $+$ terminal.

Suppose we put the ideal flashlight battery and some resistor in series, as in Fig. A-4b, with the battery's positive terminal toward b . We can adapt the general expression for going from a to b in Fig. A-4a,

$$V_{ab} = -\mathcal{E}_{ab} + R_{ab}I_{ab},$$

where \mathcal{E}_{ab} is the emf encountered going from a to b , R_{ab} is the resistance between a and b , and I_{ab} is the current flowing from a to b , to our case:

$$V_{ab} = -\mathcal{E}_{ab} + I_{ab}R_{ab} = -\mathcal{E}_{-+} + I_{ab}R_{ab} = -1.5 \text{ V} + I_{ab}R_{ab}.$$

If we connect a and b by a wire, so $V_{ab} = 0$ we get $1.5 \text{ V} = IR$ as we should.

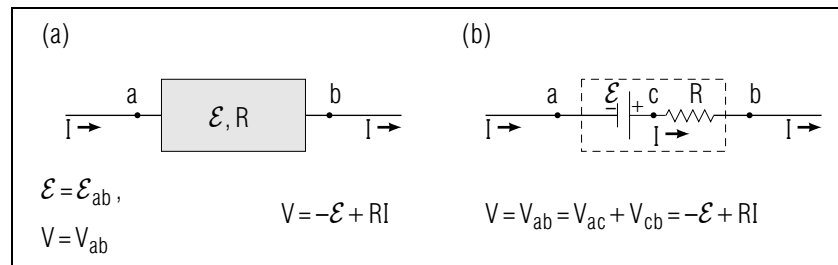

Fig. A-4: (a) General two-terminal system. (b) Equivalent two-terminal system.

Now suppose we turn the flashlight battery around in Fig. A-4b so its $(+)$ terminal is encountered first in going from a to b . Then:

$$V_{ab} = -\mathcal{E}_{+-} + I_{ab}R_{ab} = +\mathcal{E}_{-+} + I_{ab}R_{ab} = +1.5 \text{ V} + I_{ab}R_{ab}.$$

Again we connect a and b with a wire so $V_{ab} = 0$ and we get $-1.5 \text{ V} = I_{ab}R_{ab}$. Since R is always positive, this means that I_{ab} is negative. Now I_{ab} is the current flowing from a to b so a negative value merely means that the current flows the other way (from b to a). This is perfectly logical since we reversed the battery.

The general relation (A-1), or the equivalent relation (A-2), applies to any two-terminal system, no matter how complex (as long as the current through it is not too large). But the potential drop $V = -\mathcal{E} + RI$ across the two-terminal system in Fig. A-4a is the same as that across an equivalent system, illustrated in Fig. A-4b, which consists of an *ideal* emf source (having an emf \mathcal{E} equal to that of the original system) in series with a resistor (having a resistance R equal to that of the original system). Hence we arrive at the following useful conclusion, sometimes called “Thevenin’s theorem”:

$$\boxed{\text{Any two-terminal system (as long as the current through it is not too large) can be represented in a circuit diagram by an ideal emf source in series with a resistor.}} \quad (\text{A-7})$$

By representing every two-terminal system in this way, any circuit diagram becomes very simple since it contains then no complex systems, but merely *ideal* emf sources and resistors.

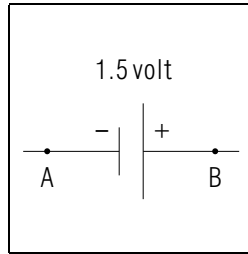

Fig. A-5.

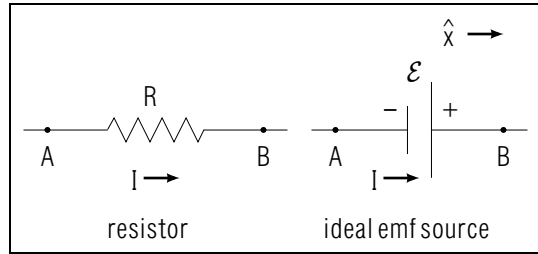

Fig. A-6.

Understanding the Relation between Potential and EMF In Ideal Sources (Cap. 1)

A-1 *Example:* (a) If an ideal battery has an emf of 12 volt, what is the potential drop across this battery from its positive to its negative terminal? What is the potential drop from the negative to the positive terminal? (b) *Interpretation:* What are the potential drops V_{AB} and V_{BA} across the system shown in Fig. A-5 (*Answer: 3*)

A-2 *Properties:* Answer the following questions for potential drop and for emf. (a) What algebraic symbol usually represents each quantity? (b) What is the SI unit of each quantity? (c) Which of the following is a reasonable magnitude for this quantity measured between the terminals of a flashlight battery: 0.02 volt, 2 volt, 20 volt? (*Answer: 8*)

A-3 *Comparing relations:* (a) Use the unit vector \hat{x} to describe the (approximate) direction of the *coulomb electric force* \vec{F}_{c+} on a positively charged particle in each of the systems shown in Fig. A-6. (b) If the \vec{F}_{c+} has the direction you indicated in part (a), what are the possible senses of current flow through each system? (c) Through a resistor, does the current always have a sense roughly along the direction of \vec{F}_{c+} or can the current have either sense? Answer the preceding question for an ideal emf source. (*Answer: 6*) (*Suggestion: [s-6]*)

A-4 *Organization of relations:* In Fig. A-6, $R = 2.0$ ohm, $\mathcal{E} = 12$ volt, and $I = 3.0$ ampere (for both systems). (a) What is the potential drop V_{AB} for each system? (b) Suppose that the current I has the same magnitude 3.0 ampere, but a sense opposite to the one shown in Fig. A-6. For each system, is the value of the potential drop V_{AB} the same or different compared with the value found in part (a)? If the value is different, what is it? (*Answer: 1*) (*Suggestion: [s-8]*)

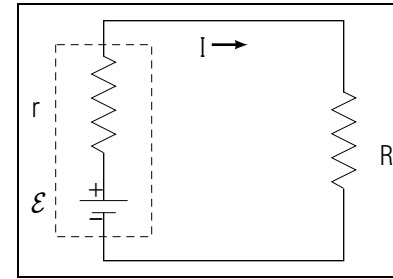

Fig. A-7.

Finding Potential Drops Across Systems (Cap. 2)

Now: Go to tutorial section A.

A-5 Figure A-7 shows a circuit diagram of a real battery which has an emf \mathcal{E} and a resistance r , and which is connected to a resistor so that the same current I flows through both systems. (a) If $\mathcal{E} = 1.5$ volt, $r = 1.0$ ohm and $I = 0.2$ ampere, what is the potential drop V from the positive terminal to the negative terminal of the battery? (b) Now suppose that the resistor R is replaced by a battery which has an emf larger than 1.5 volt. This new battery is connected so as to produce a current which has a magnitude of 0.1 ampere and a sense opposite to that shown in Fig. A-7. What then is the potential drop V from the positive terminal to the negative terminal of the battery shown in Fig. A-7? (*Answer: 12*) (*[a-1], [a-2]*)

A-6 A 1.5 volt flashlight battery has an internal resistance of 1.0 ohm. (a) Draw a circuit diagram of the battery. (b) What is the potential difference between the terminals of this battery when they are unconnected so that no current flows between them? (c) Suppose a resistive wire is connected to the two terminals so that a current of 1.3 ampere flows through the battery. What then is the potential difference between the terminals of the battery? (*Answer: 15*) (*Suggestion: [s-4]*)

More practice for this Capability: [p-1], [p-2]

Knowing About Symbols for General Two-Terminal Systems

A-7 (a) Two batteries have emfs \mathcal{E}_1 and \mathcal{E}_2 and resistances r_1 and r_2 . Draw a circuit diagram showing these two batteries connected in parallel. (b) *Review:* Consider the two ideal emf sources shown on your diagram. Are they connected in parallel? (*Answer: 5*)

SECT.

B

CIRCUIT ANALYSIS

As we have seen, any two-terminal system is equivalent to an ideal emf source in series with a resistor. Hence any circuit of two-terminal systems, no matter how complex, can always be represented as a circuit of ideal emf sources and resistors connected together.

► *Goal*

We usually have some limited information about any circuit of two-terminal systems (such as batteries and resistors). The goal of circuit analysis is then to use this limited information to find other information of interest. (For example, given information about the values of all the emfs and all the resistances in a circuit, we might be interested in finding the current flowing through each two-terminal system.)

BASIC PRINCIPLES

We can achieve the preceding goal by using the principles which we have already studied. Let us therefore briefly summarize these principles.

► *Circuit principles*

In statement (E-1) of Unit 423 and statement (E-2) of Unit 423 we presented two basic principles relating the steady currents and the potential drops in any circuit. The first of these principles, which relates various currents in a circuit, can be summarized as follows:

$$\text{At any junction, } I_{\text{in}} = I_{\text{out}} \quad (\text{B-1})$$

The second principle, which relates various potential drops in a circuit, can be summarized:

From any point a to any point b , V_{ab} is the sum of the potential drops along *any* path from a to b .

(B-2)

► *System characteristics*

From Relation (F-4) of Unit 423 we also know that every individual two-terminal system can be characterized by a relation between the current through the system and the potential drop between its terminals. In particular, by Relation (A-2) of Unit 424

$$\text{for resistor, } V = RI \text{ (along sense of current)} \quad (\text{B-3})$$

(Thus the potential drop opposite to the sense of the current is equal to $-RI$.) Furthermore, by Def. (A-6) in the preceding section

$$\text{for ideal emf source, } V_{-+} = -\mathcal{E} \quad (\text{B-4})$$

(Thus the potential drop V_{-+} from the $-$ to the $+$ terminal is equal to $-\mathcal{E}$.)

STRATEGY

To solve the problem of finding unknown quantities in a circuit, we can then use these main steps:

► *Description*

Describe the relevant currents and potential drops by:

- (1) Drawing a circuit diagram
- (2) Drawing arrows indicating conveniently chosen senses for describing the currents (e.g., senses suggested by the flow of hypothetical positively charged particles).
- (3) Choosing symbols for unknown currents and other unknown quantities.

► *Planning*

To find relations involving the unknown quantities, proceed as follows:

- (1) To relate the various currents in the circuit, choose one or more junctions and apply the relation $I_{\text{in}} = I_{\text{out}}$ of Eq. (B-1).
- (2) To relate the various potential drops in the circuit, choose one or more convenient pairs of points and express the potential drop between these points in terms of the sums of the potential drops (across individual systems) along alternate paths between these points.
- (3) In the preceding step, use Eq. (B-3) to express the potential drop across each resistor in terms of its resistance and the current through it. Similarly, use Eq. (B-4) to express the potential drop across each ideal emf source in terms of its emf (being careful to watch signs).
- (4) In some cases it may be convenient (although not necessary) to undertake the preceding steps after first simplifying the initial circuit diagram by combining resistors connected in series or parallel.

► *Implementation*

Combine the simultaneous equations obtained in the preceding plan and solve these equations for the unknown quantities.

► *Checking*

- (1) Check the magnitudes, signs, and units of all quantities obtained in the solution.
- (2) Check that the currents at every junction satisfy the relation $I_{\text{in}} = I_{\text{out}}$ of Eq. (B-1), and that the potential drops between any two points are properly related to individual potential drops according to Rule (B-2).

Example B-1: SOLVING A CIRCUIT PROBLEM

The circuit diagram in Fig. B-1 shows a fairly complicated circuit consisting of two batteries with negligible resistances (i.e., ideal emf sources) connected to several resistors. What are the currents flowing through each battery and each resistor?

► *Description*

We have indicated by arrows in the diagram convenient senses relative to which we may specify the unknown currents. (We chose these senses by imagining positively charged particles flowing out of the positive terminals of the batteries and then joining at the point b to flow along the path containing the $2.5\ \Omega$ resistor.) Let us call I_1 the current flowing in the indicated sense through the 15 volt battery and the $1.0\ \Omega$ resistor, I_2 the current flowing in the indicated sense through the 10 volt battery and the $2.0\ \Omega$ resistor, and I the current flowing in the indicated sense through the $2.5\ \Omega$ and $3.5\ \Omega$ resistors.

► *Planning*

At the junction point b , the total current into the junction is $I_1 + I_2$, while the current out of this junction is I . Hence the principle Eq. (B-1) implies that these currents are related so that

$$I_1 + I_2 = I \quad (\text{B-5})$$

(The same relation also holds at the junction a where the current I flows in and the currents I_1 and I_2 flow out.)

Let us now consider the potential drop V_{ab} from point a to point b as the sum of the potential drops along various alternate paths. (For simplicity, we shall omit all units, it being clearly understood that all potential drops are expressed in volt, all currents in ampere, and all resistances in

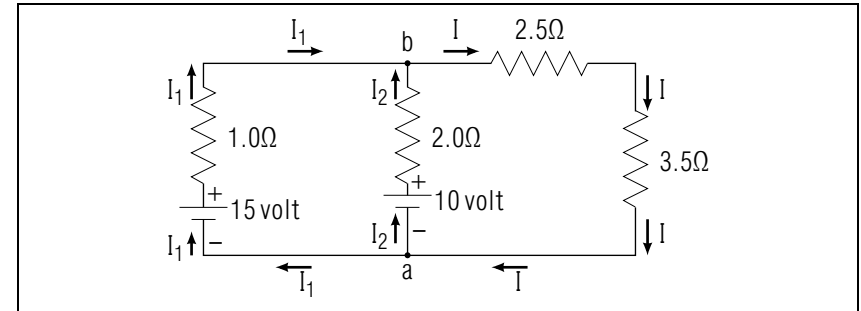

Fig. B-1: An electric circuit consisting of two batteries connected to several resistors.

ohms.) Along the path from a to b through the 15 volt battery and the $1.0\ \Omega$ resistor

$$V_{ab} = -15 + 1.0I_1 \quad (\text{B-6})$$

where the potential drop across the battery is negative since the path from a to b traverses the battery from its $-$ to its $+$ terminal. Similarly, along the path from a to b through the 10 volt battery and the $2.0\ \Omega$ resistor,

$$V_{ab} = -10 + 2.0I_2 \quad (\text{B-7})$$

Finally, along the path from a to b through the $3.5\ \Omega$ and $2.5\ \Omega$ resistors,

$$V_{ab} = -3.5I - 2.5I = -6.0I \quad (\text{B-8})$$

where the potential drop across each resistor is negative since the path from a to b traverses each resistor in a sense opposite to that of the current I .

Equating the potential drops along the alternate paths specified by Eq. (B-6) and Eq. (B-7) we then get

$$-15 + 1.0I_1 = -10 + 2.0I_2 \quad (\text{B-9})$$

Similarly, equating Eq. (B-6) and Eq. (B-8), we get

$$-15 + 1.0I_1 = -6.0I \quad (\text{B-10})$$

The three relations (B-8), (B-9), and (B-10) are sufficient to find the three unknown currents I_1 , I_2 , and I .

► *Implementation*

The relation (B-9) implies that

$$I_1 = 2I_2 + 5 \quad (\text{B-11})$$

Similarly, the relation (B-10) implies that

$$I_1 + 6I = 15$$

or, replacing I by its value $I = I_1 + I_2$ from Eq. (B-5),

$$7I_1 + 6I_2 = 15 \quad (\text{B-12})$$

Substituting the value for I_1 obtained in Eq. (B-11), we then get

$$(14I_2 + 35) + 6I_2 = 15$$

$$20I_2 = -20$$

or

$$I_2 = -1 \quad (\text{B-13})$$

By Eq. (B-11), we then get $I_1 = -2 + 5 = 3$. By Eq. (B-5) we then get $I = I_1 + I_2 = -1 + 3 = 2$. Since the current unit is ampere, we have thus obtained the final results

$$I_1 = 3 \text{ ampere}, I_2 = -1 \text{ ampere}, I = 2 \text{ ampere} \quad (\text{B-14})$$

► *Checking*

The minus sign for the current I_2 means merely that the actual sense of this current is opposite to the chosen sense indicated in the circuit diagram. Thus the positive currents flowing into the junction a are $-I_2 = 1$ ampere and $I = 2$ ampere. The sum of these currents (i.e., 3 ampere) is properly equal to the positive current $I_1 = 3$ ampere flowing out of this junction.

Systematically Relating Currents and Potentials (Cap. 3)

Now: Go to tutorial section B.

B-1 The following procedure is used to find the emf and resistance of a battery (or any other system). When the terminals of the battery are not connected (so that no current flows through the battery), the potential difference between these terminals is measured and found to be 2.0 volt. Then the terminals are connected by a resistor so that a current of 1.0 ampere flows through the battery. The potential drop

across the battery is again measured and found to be 1.8 volt. What are the emf and resistance of the battery? (*Answer: 10*) (*Suggestion: [s-12]*)

B-2 The circuit diagram in Fig. B-2 shows the battery, ignition system, and headlights of an automobile. (a) Use the symbols on the circuit diagram to write three expressions for the potential drop V_{AB} and to write an equation relating the currents I_1 , I_2 , and I . (b) Use the equations found in part (a) to answer these questions: If the headlights are turned off, so that I_2 becomes zero and the current I through the battery decreases, does the potential drop V_{AB} increase or decrease? Does the current I_1 through the ignition system increase or decrease? To provide maximum current through the ignition system while starting the car, should the headlights be turned off or on? (*Answer: 2*)

B-3 A small light bulb with resistance 2.0 ohm (in operation) is connected to the terminals of a 1.5 volt battery which has a resistance of 0.1 ohm. (a) Find the magnitude of the current I through the battery by writing two different expressions for the potential drop V_{ab} from the positive to the negative terminal of the battery. (b) Solve this problem again, but this time describe the current relative to a chosen sense opposite to the sense used in part (a), and write two expressions for the potential drop V_{cd} from the negative to the positive terminal of the ideal part of the emf source. (*Answer: 11*) (*Suggestion: [s-10]*)

B-4 To measure the current through a wire in a circuit, one can cut the wire and connect the ends to the terminals of an “ammeter,” a device which measures the current flowing through it (Fig. B-3). However, because the wires and connections inside the ammeter have a resistance R_A , inserting the ammeter into the circuit slightly decreases the current flowing in the wire. (a) Use the symbols given in Fig. B-3 to express the original current I , flowing through the wire before the ammeter was inserted, in terms of the current I_A through the ammeter. (b) An ammeter is most useful if the measured current I_A is very nearly equal to the original current I . Should a good ammeter have a large or a small resistance R_A ? (*Answer: 7*) (*Practice: [p-3]*)

SECT.

C

 POWER AND ENERGY TRANSFORMATIONS

POWER DELIVERED BY VARIOUS FORCES

► *Coulomb power*

When a steady current flows through a two-terminal system, work is ordinarily done on the moving charged particles by both coulomb and non-coulomb forces. For example, suppose that during some small time interval dt , a small amount dQ of charge enters the system at terminal a and leaves the system at terminal b . (See Fig. C-1.) The coulomb work δW_c done in this process on the moving charged particles in the system is then obtained by multiplying the potential drop (or coulomb work per unit charge) $V = V_a - V_b$ from a to b by the charge dQ passing through the system. Thus

$$\delta W_c = V dQ \quad (\text{C-1})$$

Correspondingly, the power \mathcal{P}_c (or work *per unit time*) delivered to the moving charged particles by coulomb forces is simply obtained by dividing the work δW_c in Eq. (C-1) by the corresponding time dt . Thus

$$\mathcal{P}_c = \frac{\delta W_c}{dt} = V \frac{dQ}{dt}$$

or

$$\boxed{\mathcal{P}_c = VI} \quad (\text{C-2})$$

► *Non-coulomb power*

Suppose that the system has also an emf \mathcal{E} which specifies the non-coulomb work done *per unit charge* on a particle moving through the system from terminal a to terminal b . Then the non-coulomb work δW_{nc} done on the moving charged particles in the system when a small amount of charge dQ passes through the system is simply equal to

$$\delta W_{nc} = \mathcal{E} dQ \quad (\text{C-3})$$

The power \mathcal{P}_{nc} delivered to the charged particles by non-coulomb forces is then simply obtained by dividing Eq. (C-3) by the corresponding time dt . Thus we get, analogously to Eq. (C-2),

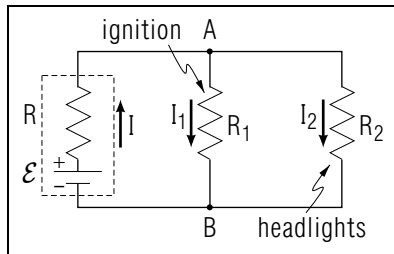

Fig. B-2.

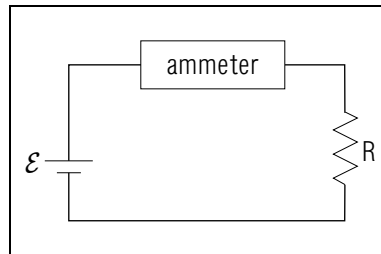

Fig. B-3.

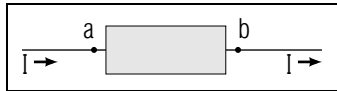

Fig. C-1: Current flowing through a two-terminal system.

$$\mathcal{P}_{nc} = \mathcal{E}I \quad (\text{C-4})$$

► *Total power*

The power \mathcal{P} delivered to the charged particles in the system by *all* forces is then simply the sum of the powers delivered by coulomb and non-coulomb forces. Thus, by Eq. (C-2) and Eq. (C-4),

$$\mathcal{P} = \mathcal{P}_c + \mathcal{P}_{nc} = (V + \mathcal{E})I \quad (\text{C-5})$$

But the total work done on the moving charged particles in a steady state is used entirely to supply the energy lost by the moving charged particles to the random internal energy of the system. Accordingly, Eq. (C-5) describes also the rate at which the random internal energy of the system increases as a result of the current flowing through the system. This increased random internal energy manifests itself then by an increased temperature of the system. *

* As current flows through a system, the random internal energy of the system does not increase indefinitely since the system also loses some of its random internal energy by interaction with its environment (e.g., the system loses energy to the surrounding air.)

► *Total power and resistance*

According to the general relation in Relation (F-4) of Unit 423, the steady current I through a system is such that $RI = V + \mathcal{E}$, where R is the resistance of the system. Thus the power \mathcal{P} in Eq. (C-5) is just equal to

$$\mathcal{P} = (RI)I = RI^2 \quad (\text{C-6})$$

Thus we see that the power dissipated into random internal energy is just related to the resistance R of the system and to the current I through it. (For example, since the resistance of an ideal emf source is zero, no power is dissipated in such an *ideal* source.)

POWER DELIVERED TO A RESISTOR

If a two-terminal system is simply a resistor, its emf is zero since only coulomb work is done on the charged particles moving through a resistor. Then the total power delivered to the charged particles in the resistor, and thus also dissipated into random internal energy of the resistor, is simply given by Eq. (C-2),

$$\mathcal{P} = VI \quad (\text{C-7})$$

Many practical applications use this increase in the random internal energy (and resulting temperature rise) of a resistor when an electric current flows through it. For example, an electric heater (or toaster) consists merely of a coiled-up wire which is heated when an electric current is made to flow through it. Similarly, in an incandescent light bulb the current flowing through a thin wire inside an evacuated glass bulb makes this wire so hot that it emits light.

► *Alternate expressions*

The current I through a resistor and the potential drop V across its terminals are related by Ohm's law, $RI = V$. Hence the relation (C-7) for the power delivered to a resistor can be expressed in useful alternate ways involving the resistance R of the resistor. For example, since $V = RI$, Eq. (C-7) can also be written as

$$\mathcal{P} = (RI)I = RI^2 \quad (\text{C-8})$$

Similarly, since $I = V/R$, Eq. (C-7) can also be written as

$$\mathcal{P} = V \left(\frac{V}{R} \right) = \frac{V^2}{R} \quad (\text{C-9})$$

When SI units are used for all quantities, the power is properly expressed in terms of the unit joule/second = watt.

► *Dependence on I*

The relation (C-8) shows explicitly that the power delivered to a resistor with fixed resistance R is proportional to the *square* of the current flowing through the resistor. For example, if the current is 3 times as large, the power is $3 \times 3 = 9$ times as large. [This result is also obvious from Eq. (C-6) since a 3 times larger current I is, by Ohm's law, also accompanied by a 3 times larger potential drop V .]

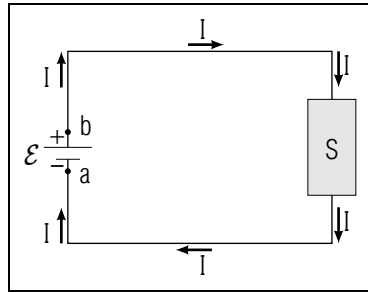

Fig. C-2: An ideal emf source connected to a two-terminal system.

ENERGY TRANSFORMATIONS IN A CIRCUIT

Consider the circuit of Fig. C-2 in which an ideal emf source is connected to a two-terminal system S (which may consist of resistors and other devices). What happens to the various energies in the circuit as a result of the current flow?

As charged particles move through the emf source from a to b , non-coulomb energy (e.g., chemical energy) is supplied to the particles so as to increase their electric coulomb potential energy. As the particles then move from b to a through the system S , the electric potential energy of the particles is converted into random internal energy of this system (or possibly also other forms of energy, such as mechanical energy, if the system S contains electric motors or similar devices). The net result of the entire preceding process is then the transformation of the initial non-coulomb energy supplied by the emf source into the final energy supplied to the system S . The electric coulomb potential energy of the moving charged particles serves merely as an intermediary in this energy-transformation process.

ANALOGY TO OTHER KINDS OF ENERGY TRANSFORMATIONS

The preceding energy conversion process is analogous to other familiar energy conversion processes. For example, muscular energy may be used to lift a weight and thus to increase its gravitational potential energy. When the weight then descends, its gravitational potential energy can be used to supply energy to some piece of machinery (e.g., to a pendulum clock). The net result of the preceding process is then a transformation of the initial muscular energy into the final energy supplied to the piece of machinery. The gravitational potential energy of the weight serves merely

as an intermediary in this energy-transformation process.

► *Electric energy transmission*

The preceding comments indicate how electric currents can be used to transmit energy over long distances. For example, chemical energy supplied by the burning of oil may be used at an electric power station to produce the emf necessary to increase the electric potential energy of charged particles (electrons). The current due to these moving charged particles can then flow through long wires extending from the power station to a distant city. When the current flows through various devices in this city, the energy of the moving charged particles is then converted into the random internal energy of heated ovens, the mechanical energy of electric motors, and all the other forms of energy our industrial society consumes in such vast quantities.

Relating Power To V , I , \mathcal{E} , and R (Cap. 4b)

C-1 A current of 0.20 ampere flows through a small calculator which is powered by a battery pack having an emf of 2.5 volt. For the precision desired here, the resistance of the battery pack is zero so that the potential difference between its terminals is 2.5 volt. (a) What is the power delivered by the battery pack to the charged particles moving in the calculator circuits? (b) What is the power lost by these particles through conversion to random internal energy (largely to the energy providing light in the numerical display)? (*Answer: 4*)

C-2 (a) Express the unit watt in terms of the more familiar units joule and second. (b) What algebraic symbol usually represents power? (c) Household electrical appliances usually operate with an average potential difference of 120 volt between their terminals, and have currents of up to a few amperes. Which of the following is a reasonable value for the power converted to random internal energy in a desk lamp: 2 watt, 200 watt, 2×10^6 watt? (*Answer: 9*)

C-3 Consider a resistor which has a resistance R , a potential difference V between its terminals, and which has a current I through it. (a) In this resistor, what is the power \mathcal{P} converted to random internal energy? Express your answer in these three ways: in terms of I and V ; in terms of I and R , and in terms of V and R . (b) Suppose the potential difference between the terminals of R is made 3 times as large as before. Is the power \mathcal{P} now 3, $1/3$, 9, or $1/9$ times as large as before? (*Answer: 13*)

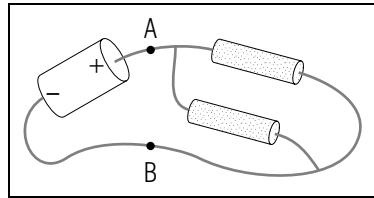

Fig. C-3.

C-4 A 100 watt light-bulb operates on a household circuit so that there is an effective potential difference of 120 volt between its terminals. What is the resistance of a 100 watt light bulb? What is the effective magnitude of the current through it in household operation? (*Answer: 20*)

Relating Powers Delivered In a Circuit (Cap. 4a)

C-5 Figure C-3 shows two resistors which have resistances 30 ohm and 40 ohm, and which are connected to a 12 volt battery with negligible resistance. (a) What is the potential drop V_{AB} across the resistors? (b) For each resistor, what is the power converted to random internal energy? (c) *Review:* What is the current through each resistor and through the battery? (d) What is the power delivered by non-coulomb work done in the battery? (e) Is the power delivered to the particles moving in this circuit equal to the power lost by these particles, as it should be? (*Answer: 17*)

C-6 A battery has negligible resistance and so produces between its terminals a constant potential difference of 12 volt. Two resistors, having resistances of 40 ohm and 20 ohm, can be connected either in series or in parallel, and can then be connected to the terminals of the battery. (a) If the resistors are connected in series, what is the current through each of them? What power in each resistor is converted to random internal energy? What is the power delivered by the battery? (b) Answer the preceding questions if the two resistors are connected in parallel. (c) Check your answers for parts (a) and (b) to assure that the sum of the powers converted to random internal energy in the resistor is equal to the power delivered to these particles in the battery. (*Answer: 14*) (*Suggestion: [s-3]*)

SECT.

D ALTERNATING CURRENTS

Up to now we have only discussed situations where all electric quantities (such as currents, potentials, and emf) are constant in time. But in many interesting cases these quantities change in the course of time. In particular, the emf generated by electric power companies varies in time repetitively (in the United States, at the rate of 60 repetitions per second) in the “sinusoidal” manner indicated in Fig. D-1. (This means that the emf varies with the time like the *sine* of an angle varies with the angle.) Such an emf is called “alternating” in contrast to a time-independent emf which is called “direct.” As a result of this alternating emf, the potential difference appearing across the terminals of any wall outlet in our homes is also alternating, and the current produced in any system connected to such a wall outlet is correspondingly also alternating. Quantities which are alternating in time are called “AC” (an abbreviation derived from alternating current), while quantities which remain constant in time are called “DC” (an abbreviation derived from direct current).

► AC current in a resistor

The alternating current I through a two-terminal system is related to the alternating potential drop V across the terminals of the system. Suppose that the two-terminal system is a simple resistor for which I and V are at any instant related by Ohm’s law $RI = V$, where R is the resistance of the resistor. Then the current I through the resistor is alternating in exactly the same way as V , with the maximum of I occurring at the same instant as the maximum of V . (See Fig. D-2a and Fig. D-2b.) *

* Many two-terminal systems are more complex than simple resistors. The alternating current I through such a system may then attain its maximum value either later or earlier than when the potential drop V attains its maximum value.

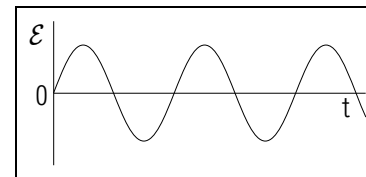
Fig. D-1: Variation of an alternating emf \mathcal{E} with the time t .

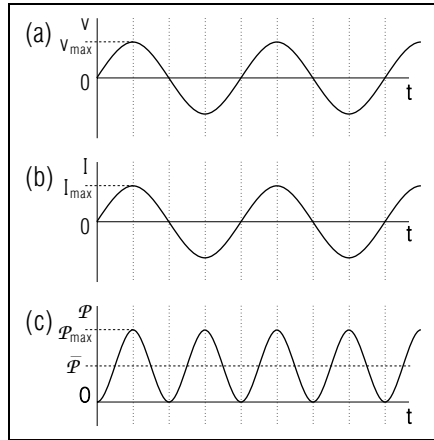

Fig. D-2: Alternating potential drop and current through a simple resistor. (a) Potential drop V versus time t . (b) Current I versus t . (c) Power $\mathcal{P} = VI = RI^2$ versus t .

Note that alternating electric quantities, such as V or I , are as often positive as negative. Hence the *average* value of V or I is zero.

► *Power*

What is the coulomb electric power delivered to a resistor as a result of an alternating current flowing through it? The mobile charged particles in a resistor always move along the direction of the coulomb electric force on them. (Whenever the electric force reverses its direction, the charged particles also move in the opposite direction.) Hence the coulomb work done on the moving charged particles, and thus also the power supplied to them, is *always positive or zero*. To examine the power more quantitatively, we note that the power delivered at any instant is given by Eq. (C-7) or Eq. (C-8) so that

$$\mathcal{P} = VI = (RI)I = RI^2 \quad (\text{D-1})$$

As shown in Fig. D-2c, this power varies in the course of time but is always positive or zero. (Indeed, RI^2 is always positive or zero since I^2 is always positive or zero, irrespective of the sign of I .)

► *Average power*

Since the power \mathcal{P} is always positive or zero, the *average* value $\overline{\mathcal{P}}$ of the power is positive and equal to

$$\overline{\mathcal{P}} = R\overline{I^2} \quad (\text{D-2})$$

where $\overline{I^2}$ is the average value of the square of the current. Thus we see that, although the power delivered to the resistor varies in the course

of time, a net positive power is nevertheless delivered to the resistor. Accordingly, alternating currents (as well as direct currents) can provide the power needed to operate electric heaters, toasters, light bulbs, and similar devices.

► *Effective values*

As mentioned previously, it is convenient to describe the magnitudes of alternating electric quantities, such as I or V , by “effective values” I_{eff} and V_{eff} which are merely fixed fractions of the maximum values I_{max} and V_{max} of these quantities. For a simple resistor for which Ohm’s law $RI = V$ holds at any instant, the effective values are then also related so that $RI_{\text{eff}} = V_{\text{eff}}$. Furthermore, if one defines the effective value of the current so that $I_{\text{eff}}^2 = \overline{I^2}$, the average power Eq. (D-2) delivered to a resistor can be simply written as *

$$\overline{\mathcal{P}} = RI_{\text{eff}}^2 \quad (\text{D-3})$$

* One can show by direct calculation that the average value of I^2 is equal to $\overline{I^2} = (1/2)I_{\text{max}}^2$. Hence the effective value of I is equal to $I_{\text{eff}} = \sqrt{\overline{I^2}} = I_{\text{max}}/\sqrt{2}$. [Since the effective value of I is the square root of the average (or mean) value of the square of the current, the effective value is also called the “root-mean-square” (or “rms”) value.]

UTILITY OF ALTERNATING CURRENTS

Alternating currents are very useful and common for these reasons: (1) As we shall discuss in Unit 427, alternating currents are easily produced by rotating machinery (i.e., by “electric generators”) and are easily manipulated to facilitate efficient long-distance transmission. Hence electric power is more easily generated and supplied to consumers by means of alternating rather than direct currents. (2) Most phenomena (such as the sound waves produced by speech or music) vary in time so that their conversion to electric form gives rise to alternating currents and potentials. Correspondingly, the electronic manipulation of speech or music (e.g., amplifiers, microphones, loudspeakers) and the electronic transmission of information (e.g., telephone, radio, television) all involve alternating currents.

Although alternating currents are quite important, a discussion of alternating currents in complex two-terminal systems and circuits is be-

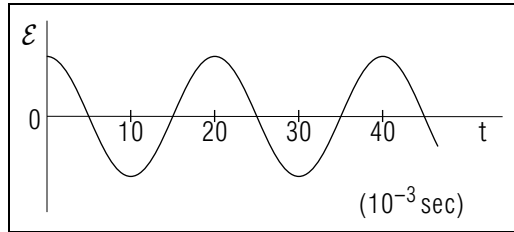

Fig. D-3.

yond the scope of this book. However, we shall comment further on some important aspects of alternating currents when we shall discuss the transmission of information by various kinds of waves.

Knowing About Alternating Currents

D-1 The graph in Fig. D-3 shows the emf \mathcal{E} produced by a generator as a function of time t . A lamp with resistance R is connected to the generator so that there is a changing current I through the lamp, a changing potential drop V across the lamp (in the sense of the current), and a changing power \mathcal{P} delivered to the lamp. What is the sign (+, -, 0) of each of the quantities \mathcal{E} , V , I , and \mathcal{P} at each of the following times shown in Fig. D-3: 5×10^{-3} sec, 10×10^{-3} sec, 15×10^{-3} sec, 20×10^{-3} sec? (*Answer: 22*) (*Suggestion: [s-1]*)

D-2 If there is an effective potential difference of 120 volt between the terminals of a 60 watt light bulb connected to an AC power source, what is the resistance of this bulb? What is the effective current through it? (*Answer: 26*)

SECT.

E SUMMARY

DEFINITIONS

ideal emf source; Def. (A-4)

IMPORTANT RESULTS

Equivalent two-terminal system: Def. (A-7)

Any two-terminal system is equivalent to an ideal emf source in series with a resistor (if current is not too large).

Circuit principles: Eq. (B-1), Rule (B-2)

At any junction, $I_{\text{in}} = I_{\text{out}}$

For any two points, V_{ab} = sum of potential drops along any path from a to b .

Characteristic relations for two-terminal systems: Eq. (B-1), Eq. (B-4)

For resistor: $V = RI$ (along sense of current)

For ideal emf source: $V_{+-} = \mathcal{E}$

Power delivered to two-terminal system: Eq. (C-2), Eq. (C-4)

coulomb power: $\mathcal{P}_c = VI$

non-coulomb power: $\mathcal{P}_{nc} = \mathcal{E}I$

Power delivered to a resistor: Eq. (C-7), Eq. (C-8), Eq. (C-9)

$$\mathcal{P} = VI = RI^2 = V^2/R$$

USEFUL KNOWLEDGE

Equivalence of any two-terminal system to a resistor and an ideal emf source in series. (Sec. A)

Alternating currents. (Sec. D)

NEW CAPABILITIES

Be able to:

- (1) Understand the following relation between potential drop and emf for an ideal emf source: $V_{+-} = \mathcal{E}$. (Sec. A)
- (2) Find the potential drop across a two-terminal system from its resistance, emf, and the current through it, or from an equivalent circuit diagram. (Sec. A, [p-1], [p-2])

- (3) Relate the currents, potentials, resistances, and emf's in a circuit by systematically applying $I_{\text{in}} = I_{\text{out}}$ and $V_{ab} = \text{sum of potential drops along any path from } a \text{ to } b$. (Sec. B, [p-3], [p-4])
- (4) For charged particles moving in a steady state:
- Relate the power delivered to the particles (by coulomb and non-coulomb work) to the power dissipated by these particles into random internal energy. (Sec. C)
 - Relate values for any of these powers to appropriate values for current, potential drop, and resistance. (Sec. C)

Tutorial aids:

Sec. A Finding potential drops along complex paths (Cap. 2)

Sec. B Systematically relating currents and potentials (Cap. 3)

Sec. F Additional problems

Systematically Relating Currents and Potentials (Cap. 3)

E-1 Figure E-1 shows a device called a “Wheatstone bridge” used to measure the unknown resistance R_x in terms of the known resistances R_1 and R_2 and the resistance R_v which can have various values depending on where the terminal indicated by (\rightarrow) is placed along the length of the resistor. To measure R_x , the resistance R_v is adjusted until the potential difference between a and b is zero (as measured by a voltmeter). For this situation, express R_x in terms of the known values of R_1 , R_2 , and R_v by using this procedure: (a) Draw arrows indicating the chosen senses of the current I_a through point a and I_b through point b . (b) Write two expressions for the potential drop V_{ab} . (c) Use the fact that $V_{ab} = 0$ to find an expression for R_x . (*Answer: 19*) (*Suggestion: [s-9]*)

E-2 Figure E-2 shows a circuit diagram of a rechargeable automobile battery (With emf \mathcal{E}_b and resistance R_b) connected to a battery charger, which is an emf source with resistance R_{ch} and emf \mathcal{E}_{ch} (slightly larger than \mathcal{E}_b). (a) Express the current I through the battery in terms of the symbols provided. (b) To safely recharge a battery, the current I must have a small magnitude. If the total resistance $R_b + R_{ch}$ of the circuit is 3.0 ohm, and the emf of the battery is 12.0 volt, what value of \mathcal{E}_{ch} produces a current of 20 ampere through the battery? (*Answer: 16*) (*Practice: [p-4]*)

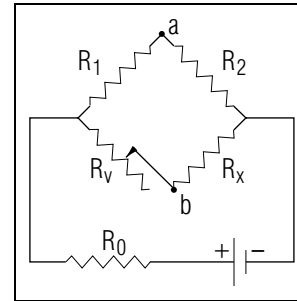

Fig. E-1.

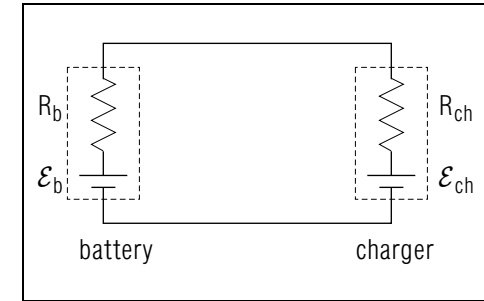

Fig. E-2.

Relating Quantities Describing Circuits (Cap. 1,2,4)

E-3 Consider the following two-terminal systems all made of identical batteries: two batteries connected in series; two batteries connected in parallel. (a) If no current flows through these systems, is the potential drop across each system larger, smaller or equal in magnitude to the potential drop across the single battery? (b) Answer the preceding question if a small current I flows into each system at its negative terminal. (*Answer: 21*)

E-4 A resistor with resistance R is connected to the terminals of an ideal battery with emf \mathcal{E} . If the resistance R is increased, does the power delivered by battery increase or decrease in magnitude? (*Answer: 25*)

SECT.

F

 PROBLEMS

Relating Power to Descriptions of Circuits

F-1 Commonly it is useful to design a circuit so that as much power as possible is delivered to some particular system (e.g., a heater or light bulb). Consider a simple circuit consisting of an emf source with emf \mathcal{E} and resistance r , connected to the terminals of a resistor having a resistance R . (a) If the resistance R is very large or very small, is the power delivered to this resistor very large or very small? (b) Use the quantities \mathcal{E} , R , and r to express the power \mathcal{P} delivered to the system. Is this expression consistent with your answers to part (a)? (c) To result in the maximum power delivered to the system, should the resistance R be very large, very small, or have some intermediate value? (*Answer: 18*) (*Suggestion: [s-7]*)

F-2 Figure F-1 shows a circuit diagram for a lightbulb which can provide three alternate brightnesses. Depending on the position of the switch, current flows between A and B through resistor 1 only, through resistor 2 only, or through both resistors 1 and 2 connected in parallel. (a) If the average potential difference between A and B is 120 volt, what are the resistances R_1 and R_2 in a lightbulb to which 100 W, 200 W, or 300 W, of power is delivered (depending on the position of the switch)? (b) When current flows through both of the resistive filaments, is the power delivered to the filament with smaller resistance larger or smaller than the power delivered to the other filament? (*Answer: 23*)

F-3 A power station delivers a power \mathcal{P}_0 to a system consisting of two connecting wires (each having resistance r) and a factory which makes use of the power delivered to it and which has a resistance R (Fig. F-2). The power delivered by the station is $\mathcal{P}_0 = IV_{ab}$, where I is the current in all parts of the circuit, and V_{ab} is the potential difference between the terminals of the station. It is desirable to minimize the power rI^2 converted to random internal energy in the connecting wires (and so to maximize the electric power delivered to the factory). (a) To achieve this end, should the current I be large (and the potential difference V_{ab} be correspondingly small) or should I be small (and V_{ab} be correspondingly large)? Why are power lines “high voltage” rather than “high amperage”? (b) If the power-delivery system is designed according to your answer to part (a), is the potential drop V_{cd} across the factory

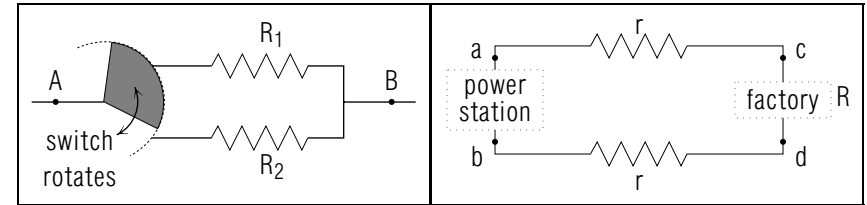

Fig. F-1.

Fig. F-2.

large or small compared with the potential drops V_{ac} and V_{cb} between the ends of the connecting wires? (c) In an efficient power-delivery system, should the resistance r of the wires be large or small compared with the resistance R of the factory? (*Answer: 28*)

F-4 *Dangers of household electricity:* Improper use of household electricity can result in electrical burns (if current flows through an extremity), in death by electrocution (if a sufficiently large current flows through the heart), or in a fire (if a sufficiently large current flows through a wire for a period of time). In each of the following situations, is the likely result a burn, electrocution, a fire, or is there no immediate danger in this situation? (a) Two wires make electrical contact in the frayed cord of a toaster, thus considerably reducing the resistance of the toaster. (b) A child, sitting on a rubber mat, pulls a plug partly out of a socket, and touches the two prongs with one of his hands. (c) A child, sitting on a rubber mat, pokes a metal object into one terminal of the wall socket. (d) A child, grounded due to contact with a pipe, pokes a metal object into one terminal of a wall socket. (e) A careless electrician “tests” a lightbulb socket by very briefly connecting its terminals with the metal blade of a plastic handled screwdriver. (*Answer: 24*) (*Suggestion: [s-11]*)

F-4 *Careless grounding in a hospital:* Figure F-3 shows a patient who is connected to an external heart pace-maker A (by means of a wire connected to his heart) and to a pressure monitor B (by means of a thin tube filled with a conducting salt solution). In addition to being connected to wall outlets (emf sources) each of these machines has appropriately been connected to ground-wire terminals at C and D . However, the points C and D are connected to the ground (G) by means of *different* wires. In the hall outside there is a vacuum cleaner which is defective in that a bare wire is in contact with its metal case, giving the case some non-zero potential relative to the ground. Thus when the case of the vacuum cleaner is connected to the ground-wire terminal at E , a small current of 1.0 ampere flows from E to G through the ground wire (which has a

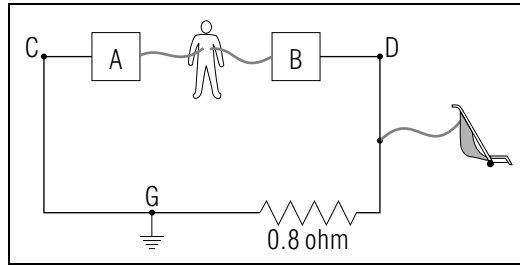

Fig. F-3.

resistance of 0.8 ohm). (a) What is the potential of the point D relative to the point G ? (b) If a janitor touches the case of the vacuum cleaner, will he be aware of this potential? (c) Since no current flows between D and E or between G and C , these pairs of points have the same potential. What is the potential difference between D and C (and thus across the patient's heart)? (d) If the resistance of the heart is 1,000 ohm, what is the current through the patient's heart? (e) Does this current exceed 10×10^{-6} ampere, the current which causes death? (f) If you were the physician in charge of this patient, how would you connect the two machines A and B so as to protect the patient? (*Answer: 27*) (*Suggestion: [s-5]*)

TUTORIAL FOR A

FINDING POTENTIAL DROPS ALONG COMPLEX PATHS

a-1 *SIMPLE SYSTEMS:* According to the discussion in the text, *any* two terminal system, with an emf \mathcal{E} and a resistance R , has between its terminals a potential drop equal to the potential drop across this system:

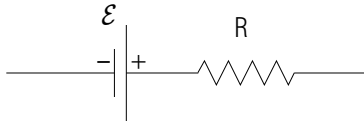

Thus to find the potential drop along any complex path through various systems one can just find and add the potential drops across individual resistors and ideal emf sources.

Therefore, let us briefly summarize how to find the potential drop across these simple systems. Then, in the next frame, we shall look at the use of these results to find potential drops along more complex paths.

Potential Drops Across Resistors and Ideal EMF Sources

System	Magnitude of V	Sign of V
Resistor (R)	$ RI $	Current sense is from the terminal with higher potential to the terminal with lower potential.
Ideal emf source \mathcal{E}	$ \mathcal{E} $	The positive terminal has a higher potential than the negative terminal.

a-2 *COMBINATIONS OF SIMPLE SYSTEMS:* Two batteries are connected as shown in the following diagram. A current I flows through both batteries along the sense indicated on the diagram.

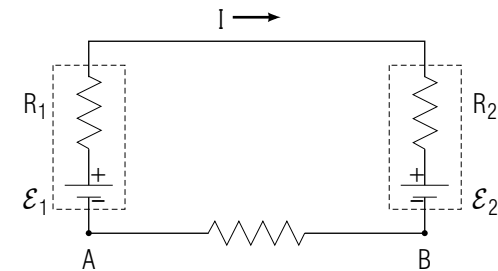

Let us find the potential drop from A to B through the two batteries by finding and adding the potential drops across each ideal emf source and resistor along the path from A to B .

System	Magnitude of V	Value of V
emf 1:	$ \mathcal{E}_1 $	$-\mathcal{E}_1$, because V is the potential drop from the negative to the positive terminal.
resistor 1:	$ R_1 I $	$+R_1 I$, because V is the potential drop along the sense of the current.
resistor 2:	$ R_2 I $	$+R_2 I$, because V is the potential drop along the sense of the current.
emf 2:	$ \mathcal{E}_2 $	$+\mathcal{E}_2$, because V is the potential drop from the positive to the negative terminal.

The total potential drop V_{AB} is therefore:

$$V_{AB} = -\mathcal{E}_1 + R_1 I + R_2 I + \mathcal{E}_2$$

Now: Go to text problem A-5.

TUTORIAL FOR B

SYSTEMATICALLY RELATING CURRENTS AND POTENTIALS (Cap. 3)

b-1 *PURPOSE:* This tutorial section should help you in solving problems of the following kind: Given the resistances and emf's of the various two-terminal systems in a circuit, find values for various currents and potential drops describing this circuit. [Equivalent problems involve using values for currents and potential drops to find resistances and emf's.]

The following principles are sufficient to solve such problems:

For any region:

$$I_{\text{in}} = I_{\text{out}}$$

For any path from a to b :

V_{ab} = sum of potential drops along any path from a to b .

For a resistor:

$V = RI$, along the sense of the current. The potential drop opposite to the sense of the current is then $-RI$.

For an ideal emf source:

$V = \mathcal{E}$, from the positive to the negative terminal. $V = -\mathcal{E}$, from the negative to the positive terminal.

Applying these principles to complex circuits is made considerably easier by the use of a systematic strategy such as the one outlined in the text and illustrated in the following frames.

b-2 *A SAMPLE PROBLEM:* Let us see how the strategy described in the text applies to a sample problem:

Problem

When the terminals of a battery are connected by a wire having negligible resistance, the current through the battery is 6.6 ampere. When the terminals of the same battery are connected by a wire having a resistance of 3.0 ohm, the current through the battery is 0.6 ampere. What is the resistance of the battery?

Solution

(1) Description

Known:

$$I_1 = 6.6 \text{ ampere}$$

$$I_2 = 0.6 \text{ ampere}$$

$$R = 3.0 \text{ ohm}$$

Desired:

$$r = ?$$

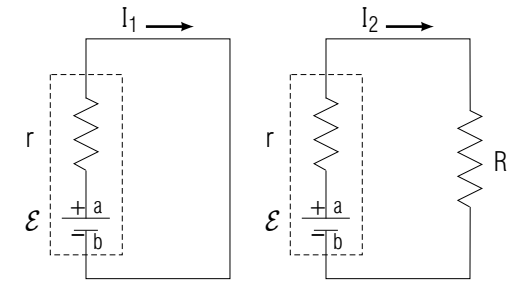

In both circuits, the current senses could have been chosen in either of two ways. For this sample solution, let us use the senses indicated.

In solving this problem, it will be useful to consider potential drops along alternate paths between the indicated points a and b . The reason is that V_{ab} is the same in both circuits because it is equal to the emf \mathcal{E} of the battery.

(2) Plan:

- The current I_1 is the same throughout the first circuit; the current I_2 is the same throughout the second circuit.
- From each circuit we can find two equal expressions for V_{ab} by considering the path through the ideal emf source and the path through the resistor (or resistors).
- In the first circuit: $V_{ab} = \mathcal{E}$, $V_{ab} = rI_1$
In the second circuit: $V_{ab} = \mathcal{E}$, $V_{ab} = rI_2 + RI_2$

(3) Implementation:

From step (c) in the plan:

$$\mathcal{E} = rI_1 \text{ and } \mathcal{E} = rI_2 + RI_2$$

Combining these equations and eliminating the undesired unknown \mathcal{E} we obtain:

$$rI_1 = rI_2 + RI_2$$

Solving for the desired unknown r results in:

$$r(I_1 - I_2) = RI_2 \text{ or } r = RI_2/(I_1 - I_2)$$

So numerically:

$$r = (3.0 \Omega)(0.6 \text{ A})/(6.0 \text{ A}) = 0.3 \text{ ohm}$$

b-3 *CHOOSING SENSES FOR CURRENTS:* In the preceding sample problem (as in many problems) no senses are specified for the currents. Thus one has to specify “chosen” senses for use in solving the problem. Any chosen senses can be used in a correct solution. But the following guidelines aid in choosing senses which are most likely to correspond to the actual senses of current flow and least likely to lead to confusion:

- (1) Through resistors, current flows from points with higher potential to points with lower potential. Thus, if the terminals of a single battery are connected by resistors, currents through the resistors have senses away from the battery’s positive terminal and towards its negative terminal
- (2) There are no regions for which current flows in, but no current flows out (or for which current flows out, but no current flows in).

Use the preceding guidelines to draw sense arrows indicating reasonably chosen senses for the currents in the following circuits.

▶

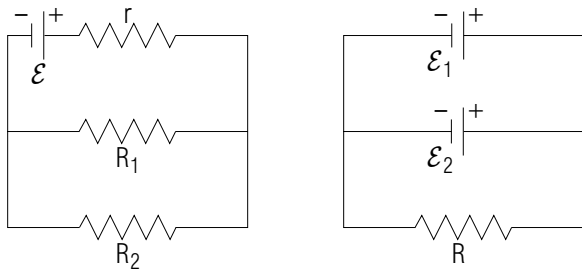

(Answer: 51)

b-4 *A PRACTICE EXAMPLE:* Two batteries, each with emf $\mathcal{E} = 2.0$ volt and internal resistance $r = 2.0$ ohm are connected in parallel, and their terminals are then connected to a light bulb which has a resistance $R = 9$ ohm when in operation. Apply the strategy illustrated in frame [b-2] to find the current I_1 through the light bulb and the current I_2 through each of the identical batteries.

- (1) Description: Describe the problem as illustrated in frame [b-2].

▶

- (2) Plan:

- (a) Apply $I_{\text{in}} = I_{\text{out}}$ to write an equation relating the currents I_1 and I_2 .

▶ _____

- (b) Consider a point A which has the same potential as the positive terminals of the battery; and a point B which has the same potential as the negative terminals of the batteries. Write two different expressions for V_{AB} .

▶ $V_{AB} =$ _____ $V_{AB} =$ _____

- (3) Combine the three equations found in part 2 so as to eliminate the undesired unknown V_{AB} , to express I_1 and I_2 in terms of \mathcal{E} , r , and R , and then to find their values.

▶ $I_1 =$ _____ $=$ _____ $I_2 =$ _____ $=$ _____

- (4) Check that your results are consistent with $I_{\text{in}} = I_{\text{out}}$ at each junction, and with $V_{AB} =$ sum of potential drops along any path from A to B .

(Answer: 55) (Suggestion: For help with algebra, see [s-2].) Now: Apply the strategy illustrated here to solve problems B-1 through B-4.

TUTORIAL FOR F

ADDITIONAL PROBLEMS

f-1 *BATTERIES IN PARALLEL AND IN SERIES:* Five identical batteries each with emf \mathcal{E} and resistance r , can be connected together in series or in parallel as indicated in this diagram:

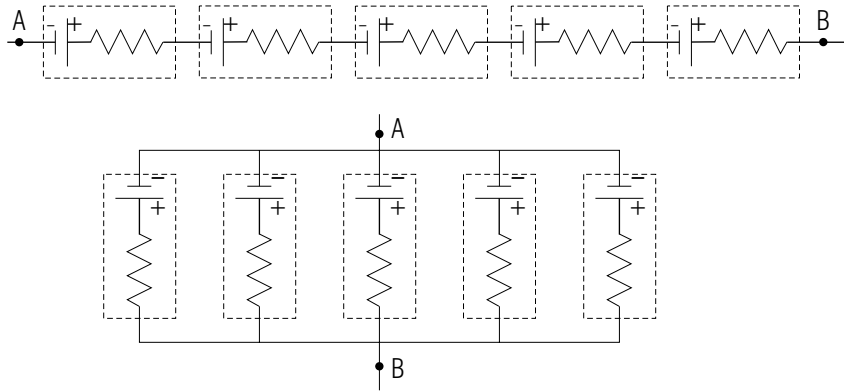

(a) If the same current I flows into each system at A (and out at B), what is the potential drop V_{AB} across each system? (b) What is the emf and the resistance of each system? (c) If several batteries with emf \mathcal{E} and resistance r are connected in series to form a system, are the resistance and the emf of this system larger, smaller, or the same in magnitude as \mathcal{E} and r ? (d) Answer the question in part (c) for a system consisting of several batteries connected in parallel. (*Answer: 59*)

f-2 *ELECTROPLAQUE CONNECTIONS IN ELECTRIC FISHES:* Some fishes have specialized “electroplaque” cells which are small emf sources. These electroplaque cells are connected differently in fresh-water fish than in salt-water fish for reasons illustrated in this problem:

An electric fish can best survive if its emf source supplies the largest possible power to the surrounding water (so as to stun prey and discourage enemies). (a) Use the following simple diagram to write an expression for the power \mathcal{P} delivered to water of resistance R by an emf source with emf \mathcal{E} and resistance r . [Express \mathcal{P} in terms of R , r , and \mathcal{E} .]

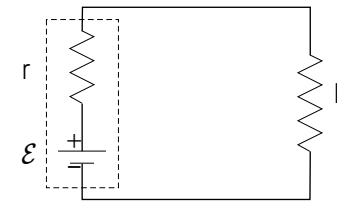

(b) For a fresh-water fish, the resistance R of the water is much larger than the resistance r of the emf source. Assume that r is negligible compared with R , and write a simplified expression for \mathcal{P} . (c) For a salt-water fish, the resistance R of the water is much smaller compared with the resistance r of the emf source. Assume that R is negligible compared to r , and use your answer to part (a) to write a simplified expression for \mathcal{P} . (d) On the basis of your preceding answers, and the results of frame [f-1], why do fresh-water fish have their electroplaque cells connected largely in series, while salt-water fish have many more electroplaque cells connected in parallel? (*Answer: 54*)

f-3 *DESIGN OF WIRES FOR CARRYING CURRENT:* In designing wires to carry current safely, a crucial consideration is the power which is converted to random internal energy in the wire when it is in use. The reason is that this increase in random internal energy corresponds to an increase in temperature, which can damage surrounding materials and cause fires.

(a) A number 18 gauge copper wire has a cross-sectional area of $8.0 \times 10^{-3} \text{ cm}^2$. Use the resistivity of copper (Table D-1) to find the power converted to random internal energy in one meter of this wire when carrying a current of 5.0 ampere.

(b) If a builder decides to use aluminum wire instead of the copper wire just described, what should be the cross-sectional area of the aluminum wire so that the power lost to random internal energy in one meter of the wire is the same as for the copper wire? (*Answer: 60*)

f-4 *CURRENTS AND POTENTIALS IN A VOLTMETER:* A “voltmeter” is a device for measuring the potential drop between two points to which its terminals are connected. The following diagram shows a voltmeter (labeled by V) connected so as to measure the potential drop from A to B in the indicated circuit including a resistor with resistance

R and a battery with emf \mathcal{E} and resistance r . However, because some small current I_V flows through the voltmeter, the potential drop V_{AB} measured by the voltmeter may not quite be equal to the potential drop V_{AB} from A to B before the voltmeter was connected. Let us explore this possible difference.

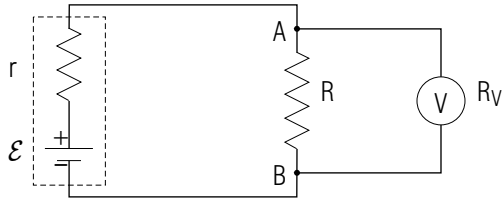

(a) Write and then combine two expressions for V_{AB} before the voltmeter is connected so as to express V_{AB} in terms of \mathcal{E} , r , and R . (b) Write for V_{AB} after the voltmeter is connected, three expressions in terms of \mathcal{E} , R , r , and the currents I_R and I_V through the resistor and through the voltmeter. (c) Use your results to part (b) to express the potential drop V_{AB} in terms of \mathcal{E} , r , R , and R_V . (d) A voltmeter is most useful if the measured potential drop V_{AB} is very nearly equal to the original potential drop V_{AB} . Should a good voltmeter have a large or a small resistance R_V ? (*Answer: 61*)

f-5 *BATTERIES NEEDED TO POWER AN AUTOMOBILE:* To travel 200 miles at 60 mile/hour, a small car requires a stored energy of about 30 kilowatt hour = 1×10^8 joule. [This energy is commonly stored as chemical energy in unburned gasoline.] An ordinary automobile battery is guaranteed by the manufacturer to provide a current of 1.0 ampere for 120 hour while maintaining a potential difference of 12.0 volt between its terminals. (a) What is the power supplied by the battery during these 120 hour? (b) What is the energy supplied by the battery during these 120 hour? (c) How many such automobile batteries would be required to provide enough energy for a small car to travel 200 miles at 60 mile/hour? (*Answer: 58*)

PRACTICE PROBLEMS

p-1 *FINDING POTENTIAL DROPS ACROSS SYSTEMS (CAP. 2):* The following drawing shows two batteries and a resistor connected together. A current I flows through the circuit with the sense indicated.

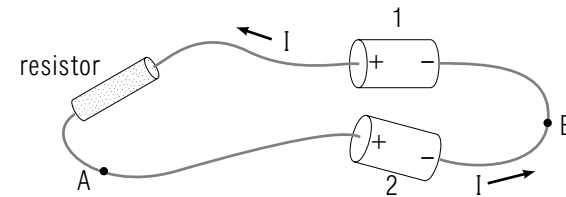

(a) Draw a circuit diagram representing this circuit.



The batteries (1 and 2) have resistances r_1 and r_2 and emfs with magnitudes \mathcal{E}_1 and \mathcal{E}_2 . The resistor has a resistance R . The current through all parts of the circuit has a magnitude I and the sense indicated in the drawing.

(b) Use the preceding symbols to express the potential drop from A to B along the path through battery 2 and along the path through the resistor and battery 1.

► Through battery 2, $V_{AB} =$ _____

Through battery 1 and resistor, $V_{AB} =$ _____

The quantities describing the batteries and resistor have these magnitudes:

$$\begin{aligned} \mathcal{E}_1 &= 2.00 \text{ volt} & \mathcal{E}_2 &= 1.50 \text{ volt} & R &= 22 \text{ ohm} \\ r_1 &= 2.0 \text{ ohm} & r_2 &= 1.0 \text{ ohm} & I &= 0.020 \text{ ampere} \end{aligned}$$

(c) Find the value of V_{AB} along each path from A to B .

► Through battery 2, $V_{AB} = \underline{\hspace{4cm}}$

Through battery 1 and resistor, $V_{AB} = \underline{\hspace{4cm}}$

(Answer: 52) (Suggestion: Review text problems A-5 and A-6, and tutorial section A.)

p-2 FINDING POTENTIAL DROPS ACROSS SYSTEMS

(CAP. 2): The following diagram shows how two batteries and a light bulb are connected in an operating flashlight. The batteries each have emf \mathcal{E} and resistance r . The lighted bulb has a resistance R and a current I flows through it with the sense indicated.

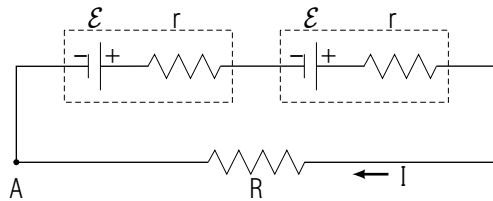

(a) Use the symbols \mathcal{E} , r , R , and I to express the potential drop V_{AA} from the point A , along the path through the batteries and then the bulb, and back to A . (b) $V_{AA} = 0$ because V_{AA} is just the potential at A minus the potential at A . Use your answer to part (a) to express the current I in terms of \mathcal{E} , r , and R . (Answer: 56) (Suggestion: Review text problems A-5 and A-6, and tutorial section A.)

p-3 SYSTEMATICALLY RELATING CURRENTS AND POTENTIALS

(CAP. 3): A power pack for a portable hand warmer consists of three identical batteries connected in parallel. Each battery has an emf $\mathcal{E} = 1.5$ volt and a resistance $R = 0.3$ ohm. (a) If a current I flows into the power pack at its negative terminal (and out at its positive terminal) what is the value of the current through each battery? (b) Use the symbols I , \mathcal{E} , and R to express the potential difference between the terminals of each battery and between the terminals of the power pack. (Answer: 53) (Suggestion: Review text problems B-1 through B-4 and tutorial section B.)

p-4 SYSTEMATICALLY RELATING CURRENTS AND POTENTIALS (CAP. 3): A 12 volt automobile battery has a resistance of 1.0 ohm. Two headlights each having a resistance of 4.0 ohm are connected in parallel and then to the terminals of the battery. Thus equal currents flow through the two headlights. What is the current through each headlight, and what is the current through the battery? (Answer: 57) (Suggestion: Review text problems E-1 and E-2, and tutorial section B.)

SUGGESTIONS

s-1 (*Text problem D-1*): Because $\mathcal{P} = I^2R = V^2/R$, the power \mathcal{P} delivered to a resistor is always positive (or zero). Equivalently \mathcal{P} is always positive because $\mathcal{P} = IV$, where I and V are either *both* positive or *both* negative.

s-2 (*Tutorial frame [b-4]*): Use your two different expressions for V_{AB} to write a single equation involving I_1 and I_2 , but not V_{AB} .

Re-express this equation (by using your relation between I_1 and I_2) in terms of I_1 or I_2 (but not both).

s-3 (*Text problem C-6*): (a) A circuit diagram helps in solving this problem. Notice that the known potential drop across the battery just equals the sum of the potential drops R_1I and R_2I across the resistors with resistances R_1 and R_2 .

s-4 (*Text problem A-6*): (a) Any two-terminal system with emf \mathcal{E} and a resistance that can be represented by a circuit diagram showing an ideal emf source (with emf \mathcal{E}) and a resistor (with resistance R) connected in series.

(b) If no current flows through a resistor, the potential drop RI across it is zero.

(*Note: For further help, see tutorial section A.*)

s-5 (*Text problem F-5*): The dangers discussed in this problem are particularly acute in modern intensive-care units, where patients are often connected to several electrical instruments by means of wires and conducting tubes which pass through the skin. The patient's electrical resistance thus does not include the large skin resistance, and so very small potential differences can produce dangerously large currents.

This problem illustrates that when hospitals are built or remodeled, extreme care should be taken to use the same wire to ground all the outlets in a particular room.

s-6 (*Text problem A-3*): In a resistor, all work is done by coulomb electric forces. Thus current must have a sense roughly along the electric force \vec{F}_{c+} on a positively charged particle.

In a general two-terminal system, both coulomb and non-coulomb work are done. Thus the total work per unit charge $IR = V + \mathcal{E}$ can have either sign (depending on which of the quantities V or \mathcal{E} has the larger magnitude). Hence, generally the current I can have either sense (depending on the sign of $IR = V + \mathcal{E}$). In an *ideal* emf source, R is very nearly zero (although never exactly zero). But, although $IR = V + \mathcal{E}$ is very nearly zero, it still has some small (positive or negative) value which determines the sense of the current.

s-7 (*Text problem F-1*): (a) If the resistance R is very large, then the current I through the resistance is very small. According to $\mathcal{P} = RI^2$, the power delivered to the resistor is then very small. Similarly, if the resistance R is very small, then the potential drop V across this resistor is also very small. According to $\mathcal{P} = V^2/R$ the power delivered to the resistor is then also very small.

(b) Apply the strategy described in tutorial section B to find an expression for the potential drop V_{ab} across the resistor (or for the current I through this resistor) in terms of \mathcal{E} , R and r . Then use $\mathcal{P} = V^2/R$ or $\mathcal{P} = RI^2$ to express the power \mathcal{P} delivered to the resistor in terms of \mathcal{E} , R , and r .

s-8 (*Text problem A-4*): *Potential*, like the potential energy of a positively charged particle, decreases in the direction of the force \vec{F}_{c+} , the coulomb force on a positively charged particle. The *potential drop* V is then positive from a point with higher potential to a point with lower potential (and negative from a point with lower potential to a point with higher potential).

In a resistor the force \vec{F}_{c+} is always directed along the direction of the current so the potential always *drops* as the current traverses the resistor in that direction.

Inside an *ideal* emf source, \vec{F}_{c+} is always directed away from the positive terminal, toward the negative terminal, so the potential always drops in that direction regardless of the direction of the current.

(Note: Suggestion [s-6] is also relevant to this problem.)

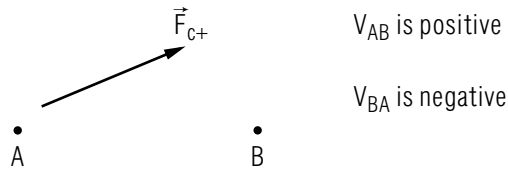

s-9 (Text problem E-1): A common mistake made in solving this problem is forgetting to use the fact that the potential drop V_{ab} is zero (because R_V has been adjusted until $V_a = V_b$). Thus you should have two separate expressions for V_{ab} , both of which are equal to zero. These two expressions provide two equations, from which the currents I_a and I_b can be eliminated (for example, by solving both equations for the ratio I_a/I_b).

s-10 (Text problem B-3): In a resistor, current has a sense from points with higher potential (such as the positive terminal of a battery) to points with lower potential (such as the negative terminal of a battery). If you chose this sense for your work with part (a), then your two circuit diagrams should be equivalent to:

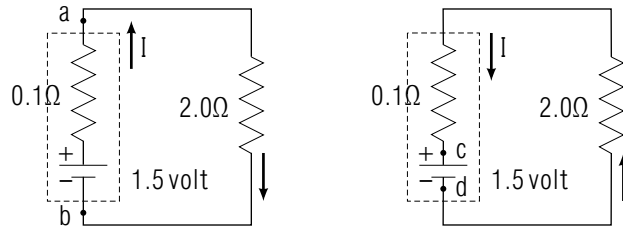

In writing expressions for the potential drops, be very careful of signs. If you have trouble, review tutorial frame [b-1].

By applying principles of circuit analysis to these two circuit diagrams, one should obtain:

$$I_L = +0.71 \text{ ampere}$$

from the first diagram. Thus the current has a magnitude of 0.71 ampere, and the same sense as the indicated chosen sense. From the diagram on the right, one should obtain:

$$I_R = -0.71 \text{ ampere}.$$

Thus this current has a magnitude of 0.71 ampere and a sense opposite to the indicated chosen sense in the diagram on the right. The real direction of the current is thus the same in the two cases and is correctly going from the positive to the negative battery terminal as it goes through the $2.0\ \Omega$ resistor.

s-11 (Text problem F-4): In considering all of the situations in this problem, remember that there is always an average potential difference of 120 volt between terminals connected directly to an electric outlet.

(a) The potential difference between the terminals remains the same, while the resistance decreases greatly. Thus the current through the cord increases greatly. The cord (or wire in the wall) may quickly become hot and start a fire.

(b) Current flows between the two terminals and through the child's hand, possibly causing an electrical burn.

(c) There is no connection between the two terminals of the wall socket. Thus no current can flow, and the child is safe (so long as he doesn't touch the other terminal).

(d) The wall terminal is often at a high potential relative to the ground. Thus current will flow through the child's body (and his heart), possibly killing him.

(e) Because the large metal screwdriver has a much smaller resistance than the thin filament of a light bulb, a large current flows through the lamp and screwdriver blade. However, none can flow through the person. If this current is allowed to continue, it could start a fire (and it is very likely to "blow" a fuse). However, no current can flow through the person because he holds only the insulating plastic handle.

s-12 (Text problem B-1): Follow the strategy discussed in text section B (and illustrated in tutorial section B). Your work should then include these results:

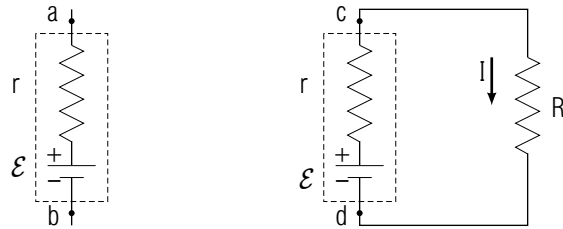
► *Description*

Known: $V_{ab} = 2.0$ volt

$V_{cd} = 1.8$ volt

$I = 1.0$ ampere

Desired: \mathcal{E} , r

► *Plan*

The solution to this problem depends on applying $|V| = |RI|$ and $|V| = |\mathcal{E}|$ to express the known potential drops V_{ab} and V_{cd} in terms of the desired quantities \mathcal{E} and r .

ANSWERS TO PROBLEMS

- +6.0 volt, -12 volt
 - same for ideal emf source; for resistor -6.0 volt
- $V_{AB} = \mathcal{E} - RI$, $V_{AB} = R_1 I_1$, $V_{AB} = R_2 I_2$, $I = I_1 + I_2$
 - V_{AB} increases, I_1 increases, off
- +12 volt, -12 volt
 - $V_{AB} = -1.5$ volt, $V_{BA} = +1.5$ volt
- 0.50 watt
 - 0.50 watt
-

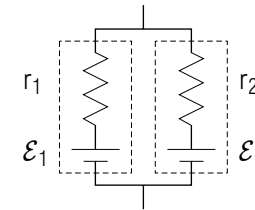

- no
- 6.
- | resistor | ideal emf source |
|---------------------|-----------------------------|
| (a) along \hat{x} | opposite \hat{x} |
| (b) along \hat{x} | along or opposite \hat{x} |
- Through a resistor, always along \vec{F}_{c+} ; through an ideal emf source, either sense relative to \vec{F}_{c+} .
- $I = I_A(R_A + R)/R$
 - small
 - V or V_{AB} , \mathcal{E}
 - volt, volt
 - 2 volt, 2 volt
 - watt = joule/sec
 - \mathcal{P}
 - 200 watt

10. emf is 2.0 volt, resistance is 0.2 ohm
11. a. $I = 0.71$ ampere
b. $I = 0.71$ ampere
12. a. 1.3 volt
b. 1.6 volt
13. a. $\mathcal{P} = IV$, $\mathcal{P} = RI^2$, $\mathcal{P} = V^2/R$
b. 9
14. a. 0.20 ampere, 0.20 ampere, 1.6 watt, 0.80 watt, $\mathcal{E}I = 2.4$ watt
b. 0.30 ampere, 0.60 ampere, 3.6 watt, 7.2 watt, $\mathcal{E}I = (12 \text{ volt})(0.90 \text{ A}) = 10.8$ watt
c. 3.6 watt + 7.2 watt = 10.8 watt
15. a.

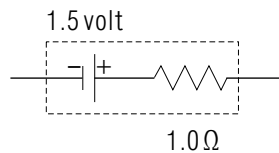

- b. 1.5 volt
c. 0.2 volt
16. a. $I = (\mathcal{E}_{ch} - \mathcal{E}_b)/(R_{ch} + R_b)$
b. 72 volt
17. a. 12 volt
b. 3.6 watt, 4.8 watt
c. 0.40 ampere, 0.30 ampere, 0.70 ampere
d. 8.4 watt
e. yes, 3.6 watt + 4.8 watt = 8.4 watt
18. a. very small in both cases
b. $\mathcal{P} = \mathcal{E}^2/(r + R)$, yes
c. intermediate
19. a. current sense is to the right through both points
b. $V_{ab} = -R_1 I_a + R_v I_b$, $V_{ab} = R_2 I_a - R_x I_b$
c. $R_x = R_v(R_2/R_1)$

20. 144 ohm, 0.833 ampere
21. a. series, larger; parallel, same
b. series, larger; parallel, larger

22.

	$\times 10^{-3} \text{ sec}$			
	5	10	15	20
\mathcal{E}	0	-	0	+
V	0	-	0	+
I	0	-	0	+
\mathcal{P}	0	+	0	+

23. a. 144 ohm, 72 ohm
b. larger
24. a. fire
b. burn
c. no immediate danger
d. electrocution
e. possibility of fire
For further explanation, see suggestion [s-11].
25. decrease
26. a. 240 ohm
b. 0.50 ampere
27. a. 0.8 volt
b. no
c. 0.8 volt
d. 8×10^{-4} ampere
e. yes
f. connect both machines to the *same* outlet [or to outlets grounded by the same wire]. For further discussion, see [s-5].
28. a. I small, V_{ab} large, V_{ab} large to minimize power lost through dissipation in the wires
b. large
c. small

51.

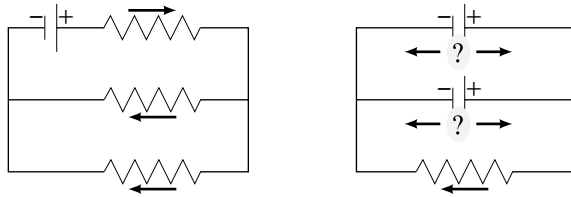

In the right diagram, either indicated sense is reasonable, but all senses should *not* be towards the left.

52. a. Circuit diagram equivalent to:

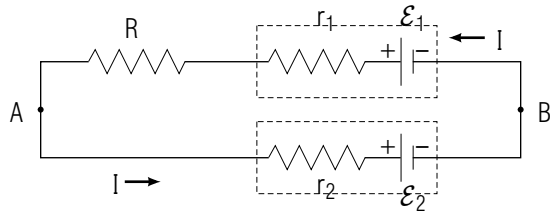

b. $r_2 I + \mathcal{E}_2, -RI - r_1 I + \mathcal{E}_1$

c. 1.52 volt, 1.52 volt

53. a. $(1/3)I$

b. $V = \mathcal{E} - (1/3)RI$

54. a. $\mathcal{P} = R\mathcal{E}^2/(R + r)^2$

b. $\mathcal{P} = \mathcal{E}^2/R$

c. $\mathcal{P} = R\mathcal{E}^2/r^2$

d. For fresh water, large \mathcal{E} produces large \mathcal{P} ; for salt water, large \mathcal{E}/r (or small r for the same \mathcal{E}) produces large \mathcal{P} .

55.(1) Diagram equivalent to:

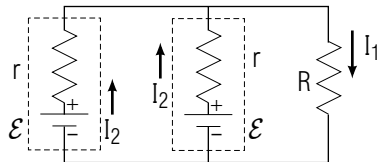

$\mathcal{E} = 2.0$ volt, $R = 9$ ohm, $r = 2.0$ ohm

(2) $I_1 = 2I_2, V_{AB} = -rI_2 + \mathcal{E}, V_{AB} = RI_1$

(3) $I_1 = 2\mathcal{E}/(2R + r) = 0.20$ ampere, $I_2 = (1/2)I_1 = \mathcal{E}/(2R + r) = 0.10$ ampere

56. a. $V_{AA} = -\mathcal{E} + rI - \mathcal{E} + rI + RI = -2\mathcal{E} + (2r + R)I$

b. $I = 2\mathcal{E}/(2r + R)$

57. 2.0 ampere, 4.0 ampere

58. a. 12 watt = 12 J/sec

b. 5.2×10^6 joule

c. 19 or 20

59. a. series, $-5\mathcal{E} + 5rI$; parallel, $-\mathcal{E} + (1/5)rI$

b. series, $5\mathcal{E}, 5r$; parallel, $\mathcal{E}, 1/5r$

c. larger, larger

d. same, smaller

60. a. 0.53 watt

b. 13×10^{-3} cm²

61. [Answers based on chosen current sense from A to B through resistor, from B to A through battery.]

a. $V_{AB} = \mathcal{E}/(1 + r/R)$

b. $V'_{AB} = RI'_R, V'_{AB} = R_V I'_V, V'_{AB} = -r(I'_R + I'_V) + \mathcal{E}$

c. $V'_{AB} = \mathcal{E}/(1 + r/R + r/R_V)$

d. large

MODEL EXAM

1. **Relating quantities describing an electric circuit.** The following diagram shows a two-terminal system, values for the currents through various parts of the system, and values for the emf or resistance describing some elements in the system.

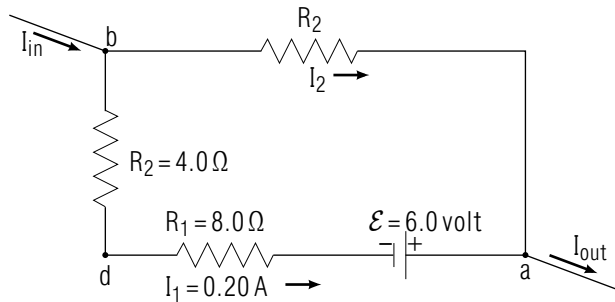

What is the potential drop V_{ab} from the point a to the point b shown in the preceding diagram? (Use the path through the point d .)

2. **Analysis of a circuit.** The following diagram shows a simple circuit consisting of an ideal emf source and resistors described by the indicated values for emf and resistance. Currents of magnitude I_1 and I_2 flow through the two resistors with the indicated senses.

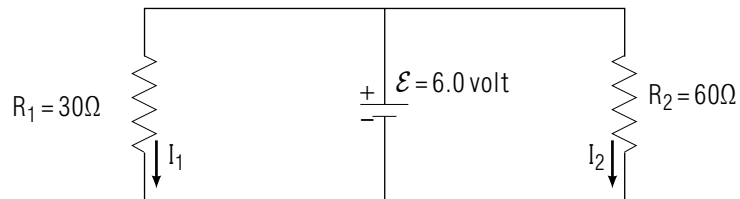

What are the magnitudes of the currents I_1 and I_2 ?

3. **Powers delivered in a simple circuit.** In the following circuit diagram an ideal emf source is connected to a resistor. Answer the following questions by circling on the answer sheet the appropriate *element or elements*.

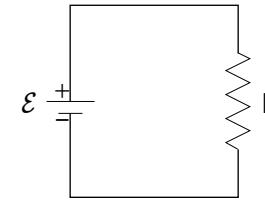

- In which element or elements is energy converted to random internal energy?
- In which element or elements do non-coulomb forces deliver power to the moving charged particles?
- In which element or elements do coulomb forces deliver power to the moving charged particles?

Brief Answers:

- 3.6 volt
- $I_1 = 0.20$ ampere; $I_2 = 0.10$ ampere
- R
 - \mathcal{E}
 - \mathcal{E}, R