

ONE-BODY DIAGRAMS AND CONTACT FORCES

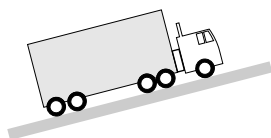
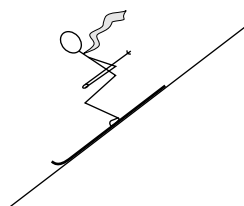

ONE-BODY DIAGRAMS AND CONTACT FORCES

by

Harry G. Dulaney, Georgia Institute of Technology, and
Peter Signell, Michigan State University

1. Introduction	
a. Overview	1
b. Mass, Acceleration, Resultant Force	1
c. Solving Unknown Force Problems	1
d. Straight-line Trajectories, No Explicit Friction	2
2. Identifying, Representing Forces	
a. Identifying Forces	2
b. Avoid Common Errors	3
c. Example: A Pulled Sled	5
3. Drawing a One-Body Force Diagram	
a. Overview	5
b. The Component Diagram	6
c. Orienting the Coordinate System	6
d. The Diagram Action Point	6
4. Complete Example Solutions	
a. A Pulled Sled	6
b. The Sled with Acceleration	8
c. Block on Incline	9
5. Connected Bodies	
a. Introduction	9
b. Connected Blocks; One on Incline, One Hanging	10
Acknowledgments	11

Title: **One-Body Diagrams and Contact Forces**

Author: Harry G. Dulaney and Peter Signell, Michigan State

Version: 10/26/2001

Evaluation: Stage 1

Length: 1 hr; 24 pages

Input Skills:

1. State Newton's laws of motion and apply them to problems involving constant forces acting on one particle traveling in one dimension (MISN-0-14), (MISN-0-15).

Output Skills (Knowledge):

- K1. Vocabulary: contact force, non-contact force, surface force, resultant force.

Output Skills (Rule Application):

- R1. Given a non-rotating object on a linear trajectory, or two such objects connected by a string or rope, possibly over a pulley, and given the information on the acceleration of the object and all forces except a surface force, determine the magnitude and direction of the surface force:
 - a. Draw a one-body diagram for each object showing the given forces acting on the object, with each force clearly labeled. Resolve those forces into components with one axis along the direction of acceleration and draw those components on another one-body force diagram.
 - b. Write Newton's second law in component form for the known forces and the resultant force.
 - c. Solve for the unknown surface force and add it to the original one-body force diagram.

THIS IS A DEVELOPMENTAL-STAGE PUBLICATION
OF PROJECT PHYSNET

The goal of our project is to assist a network of educators and scientists in transferring physics from one person to another. We support manuscript processing and distribution, along with communication and information systems. We also work with employers to identify basic scientific skills as well as physics topics that are needed in science and technology. A number of our publications are aimed at assisting users in acquiring such skills.

Our publications are designed: (i) to be updated quickly in response to field tests and new scientific developments; (ii) to be used in both classroom and professional settings; (iii) to show the prerequisite dependencies existing among the various chunks of physics knowledge and skill, as a guide both to mental organization and to use of the materials; and (iv) to be adapted quickly to specific user needs ranging from single-skill instruction to complete custom textbooks.

New authors, reviewers and field testers are welcome.

PROJECT STAFF

Andrew Schnepf	Webmaster
Eugene Kales	Graphics
Peter Signell	Project Director

ADVISORY COMMITTEE

D. Alan Bromley	Yale University
E. Leonard Jossem	The Ohio State University
A. A. Strassenburg	S. U. N. Y., Stony Brook

Views expressed in a module are those of the module author(s) and are not necessarily those of other project participants.

© 2001, Peter Signell for Project PHYSNET, Physics-Astronomy Bldg., Mich. State Univ., E. Lansing, MI 48824; (517) 355-3784. For our liberal use policies see:

<http://www.physnet.org/home/modules/license.html>.

ONE-BODY DIAGRAMS AND CONTACT FORCES

by

Harry G. Dulaney, Georgia Institute of Technology, and
Peter Signell, Michigan State University

1. Introduction

1a. Overview. In this module we help you develop understandings and techniques that are useful in almost any problem in science and engineering where forces are involved, as well as being useful for understanding every-day phenomena. To keep the new understandings and techniques in focus, we will illustrate them with a single type of problem:

- Given the mass and acceleration of an object, and all but one of the forces acting on it, determine that unknown force.

For this purpose, one must use Newton's second law.¹

1b. Mass, Acceleration, Resultant Force. Given an object's mass m and acceleration \vec{a} , Newton's second law gives the *resultant force* on the object:

$$m \vec{a} = \vec{F}_R,$$

where the resultant force on an object, \vec{F}_R , is defined as the sum of all forces which are acting on that object. Mathematically,

$$\vec{F}_R = \sum \vec{F}_i,$$

where the sum is over all of the forces \vec{F}_i , $i = 1, 2, 3, \dots$ acting on the object.

1c. Solving Unknown Force Problems. To solve the problem of determining an unknown force that is acting on an object we concentrate our attention on that object, call it "object A ." Our first task is to determine all of the other objects that are exerting forces on object A and record the characteristics of each of those forces. We do this by making a stylized sketch of object A and adding a labeled vector to the sketch for each force, as we identify it, showing its approximate direction and

¹See "Particle Dynamics; The Laws of Motion" (MISN-0-14).

magnitude. In this manner we draw the vectors for all of the forces acting on object A except for the vector representing the unknown force. Then we merely see what force vector we need to draw so that all of the forces acting on A , including the unknown one, add to the right resultant. The resultant is the force required by Newton's second law (remember that the object's mass and acceleration are *given* in the type of problem we are considering). We then add the necessary force vector to the diagram and it is the approximate answer. To find the precise direction and magnitude of the unknown force, we use the sketch as a guide and solve the component versions of Newton's second law. Finally, we check the precise answer against the approximate answer that we drew on the diagram.

1d. Straight-line Trajectories, No Explicit Friction. In this module we restrict ourselves to treating objects that are following straight-line trajectories and that are not rotating. In addition, we do not consider frictional forces explicitly but simply consider them as hidden parts of the forces exerted on the objects through surfaces with which the objects are in contact. Frictional forces are separated out from surface forces elsewhere.² Despite the restrictions imposed in this module, the understandings and techniques we develop here have much wider applicability.

2. Identifying, Representing Forces

2a. Identifying Forces. The forces acting on an object (which we will call object A) should be systematically determined by separately identifying two kinds of forces that act on the object: (1) non-contact ("action at a distance") forces; and (2) contact forces.

The only non-contact force that we deal with in this module is the gravitational force of the earth on our object. The strength of this force is what is commonly called the "weight" of the object and is commonly denoted by the symbol W . This force on the object is always directed "downward," toward the center of the earth.³

Anything that touches the object, such as ropes, surfaces, and springs, can exert a "contact force" on the object. To find these contact forces you must determine which external objects touch the object.

²See "Friction in Applications of Newton's Second Law" (MISN-0-16).

³Electric and magnetic forces are examples of other non-contact forces but these are dealt with elsewhere. See "Introduction to Electricity and Magnetism," MISN-0-121.

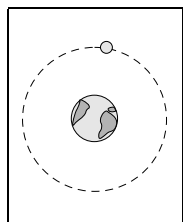

Figure 1.

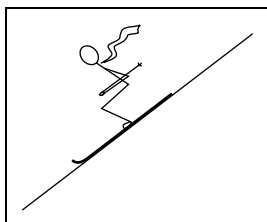

Figure 2.

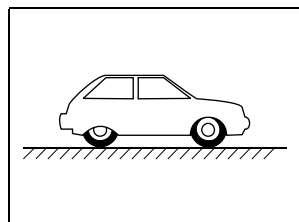

Figure 3.

2b. Avoid Common Errors. Here are some rules.

Rule 1: While identifying the forces acting on a object, include only forces for which you can identify the other objects that exert those forces. For each force that you include, you must be able to answer the question, “What other object exerts that force on the object we are examining?”

Example: A satellite moves in a circular orbit about the earth (Fig. 1). How many forces act on the satellite (assuming the atmosphere is so thin at this altitude that it can be neglected)? There is certainly one non-contact “action at a distance” force: the gravitational force of the earth on the satellite. Since nothing is in contact with the satellite, there are no contact forces. The final answer: only one force acting on the satellite; the non-contact gravitational force.

Example: A skier skis down a steep incline (Fig. 2). How many forces act on the skier, neglecting air resistance? First, there is the non-contact gravitational force of the earth on the skier (the skier’s “weight”) and the contact force of the incline on the skier. The incline is the only thing touching the skier so it exerts the only contact force present. The final answer: two forces, the incline contact force and the gravitational non-contact force. **Rule 2:** Include only external forces acting on the object. Omit internal forces, those that are acting only between different parts of the object itself.

Example: An automobile accelerates along a level road (Fig. 3). Neglecting air resistance, how many forces act on the entire auto? Two: the non-contact gravitational force of the earth on the car (its “weight”) and the contact force of the road on the car (this force is divided among the four wheels). Do not include the force of the engine on the rest of the car. This is an internal force so it is not to be included in Newton’s second law for the car. Only external forces exerted on the car by other objects in its environment can be included when solving for the motion of the entire car (how the engine’s force results in acceleration of cars will be apparent

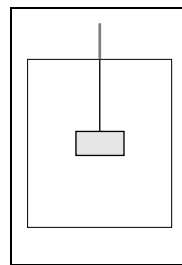

Figure 4.

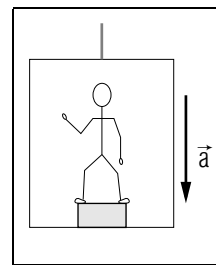

Figure 5.

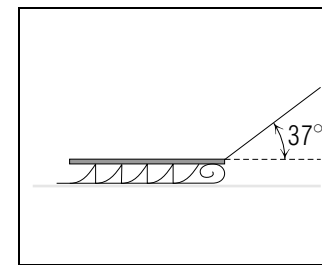

Figure 6.

only after introducing road friction into the problem).

Rule 3: Include only forces exerted on the object. Omit forces exerted by it on other objects.

Example: A block is suspended by a rope from the ceiling of an elevator that is accelerating vertically upward (Fig. 4). How many forces act on the block? Two: the non-contact gravitational force of the earth on the block and the contact force of the rope on the block. Do not include the force of the block on the rope or the force of the elevator on the rope. These forces do not act directly on the block. In order to apply Newton’s second law to a object, you must mentally isolate the object and consider only those forces acting directly on the object.

Rule 4: Use common sense in reaching conclusions about the nature of particular forces. For instance, your knowledge of a rope tells you that the force exerted on an object by a rope will always act along the direction of the rope and be directed away from the point of contact with the object.

Rule 5: Be wary of fixing the magnitude or direction of unknown forces according to intuition.

Example: A person stands on a large box which is on the floor of an elevator that is accelerating vertically downward (Fig. 5). Three forces act on the box: the non-contact gravitational force of the earth on the box, the contact force of the elevator floor on the box, and the contact force of the person on the box.

Intuition might tell you that the force of the person on the box has a magnitude just equal to the weight of the person. If so, your intuition has led you astray. If that were true, then from Newton’s third law the force of the box on the person would also be just equal to the weight of the

person. Hence, the person would have zero resultant force on her or him and zero acceleration. This cannot be true, since the person has the same downward acceleration as the elevator. In this problem the one-body technique should be applied to each object separately, with unknowns simply left as symbols.

Avoid the temptation to use intuition to guess answers. Instead, work through the entire problem systematically, letting numerical values for unknowns come from the simultaneous solution of sets of equations. Then seek intuitive support for the answer.

2c. Example: A Pulled Sled. A sled is pulled at constant speed along a horizontal surface by means of a rope, as shown in Fig. 6. Determine the forces that act on the sled and draw a one-body diagram showing those forces.

As usual, the *non-contact* gravitational force of the earth acts on the sled and is directed downward (toward the center of the earth). In addition, two objects (the rope and the snow surface) touch the sled and hence exert *contact* forces on the sled. Thus there are three forces on the sled; one non-contact force and two contact forces. Our knowledge of ropes tells us that the force of the rope on the sled is along the direction of the rope. The acceleration of the sled is zero (“constant speed”) so the resultant force is zero. Then the force of the snow surface on the sled must be such that all three forces add to zero.

3. Drawing a One-Body Force Diagram

3a. Overview. When we start working on a problem involving forces acting on an object, we almost always draw a “one-body force diagram,”⁴ so called because the diagram shows all of the forces acting on one body. If more than one object is involved, we draw a separate force diagram for each object. The diagrams we draw are somewhat stylized, in that we almost always draw the object as a rectangle. In addition, we draw the forces as though they were all exerted at the same point on the object, usually taken as the “center of mass” of the object⁵ (see Fig. 7, a stylized representation of the sled in Fig. 6 and of the forces acting on the sled).

⁴In current physics this is universally called a “free-body force diagram.” We do not use that term because in current physics the term “free body” universally means a body on which no forces are acting.

⁵For a rigorous discussion of the “center of mass” concept, see “Tools for Static Equilibrium”, MISN-0-5.

3b. The Component Diagram. Once the one-body force diagram has been drawn, the forces on it must be broken down into component forces. This is because Newton’s second law is a vector equation, so it can be expressed as a separate equation for each of the components. That is generally the form one needs for solution of the problem. The orientation of the coordinate axes, usually called the x - and y -axes, is free to be chosen by the problem solver and it is usually chosen on the basis of what would make solution easier. We urge you to draw the force components on a second one-body force diagram as in Fig. 8.

3c. Orienting the Coordinate System. You should orient your coordinate system so as to simplify the component form of Newton’s second law. In many problems, due to the constraints present, such as ropes or surfaces, it is known that the acceleration component in a particular direction is zero. In this case, coordinates parallel and perpendicular to this direction should be chosen. For example, the skier in Fig. 2 is known to have zero component of acceleration perpendicular to the surface of the snow because that component of the skier’s *velocity* is constant (it has the constant value “zero”). To make the problem easier to solve, choose one axis of the coordinate system in the direction of zero acceleration. That puts other axes in the plane of the snowy surface.

3d. The Diagram Action Point. On a one-body force diagram we draw the forces as all acting at the “center of mass” of the object, even though this may be far from where the forces actually act. This shifting of the forces’ points of action is immaterial as long as the object does not start to rotate and as long as we are not interested in how close the object is to rotational instability.

4. Complete Example Solutions

4a. A Pulled Sled. Suppose the sled described in Sect. 2c weighs 16 lb and has a 5.0 lb force exerted on it by the attached rope which is at an angle of 37° to the horizontal (see Fig. 6). Given this data, determine the force of the snow surface on the sled.

First, we sketch the one-body force diagram, putting in the forces we identified in Sect. 2c. We draw the gravity and rope forces roughly to scale and draw the surface force such that the sum of all three forces roughly equals $m\vec{a}$ (zero in this case).

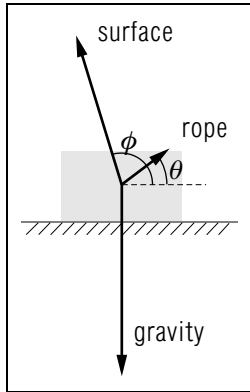

Figure 7. Forces acting in Fig. 6.

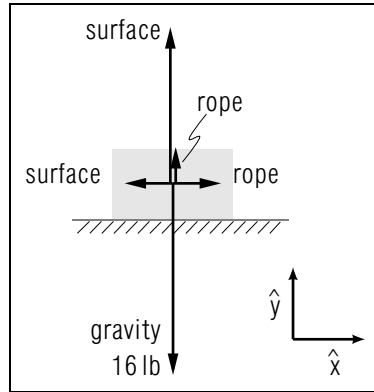

Figure 8. Components of the forces in Fig. 7.

Next, we orient the coordinate system so as to make solution as easy as possible. In this case the force of gravity is a vertical force so we pick “up” as the positive y -direction, partly because of tradition and partly so the gravitational force will have only one component that is non-zero. We pick the x -direction as being “to the right,” parallel to the snow surface, out of tradition.

Next, we resolve the known forces acting on the sled into components along the coordinate axes we have just picked. We use \vec{F}_{rope} , \vec{F}_{surface} , and \vec{F}_{gravity} to indicate the three forces and symbols without the vector signs to indicate the magnitudes of the forces (except for the magnitude of the gravitational force which is traditionally indicated by the symbol W for “Weight.”). We use θ and ϕ to indicate the angles that the surface force and the rope force make, respectively, with the positive x -axis: *Help: [S-1]*

$$\begin{aligned} F_{\text{rope},x} &= F_{\text{rope}} \cos \theta = 5.0 \text{ lb} \cos 37^\circ = 4.0 \text{ lb}, \\ F_{\text{rope},y} &= F_{\text{rope}} \sin \theta = 5.0 \text{ lb} \sin 37^\circ = 3.0 \text{ lb}, \\ F_{\text{gravity},x} &= 0, \\ F_{\text{gravity},y} &= -W = -16 \text{ lb}. \end{aligned}$$

By Newton’s second law both the x - and y -components of the resultant force must be zero (for this zero-acceleration case) so we add in the right

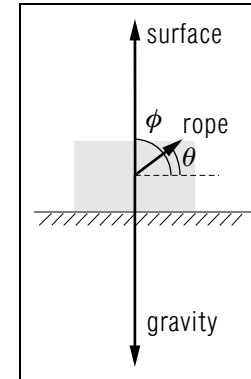

Figure 9. As in Fig. 7, but with acceleration.

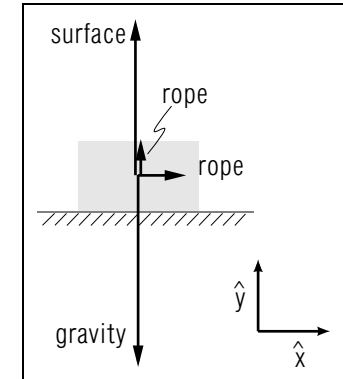

Figure 10. Force components for Fig. 9.

amount of surface force to make those resultant components zero:

$$\begin{aligned} F_{\text{surface},x} &= -4.0 \text{ lb}, \\ F_{\text{surface},y} &= 13 \text{ lb}. \end{aligned}$$

The angle and magnitude of the surface force can now be found from these two components. First, the ratio F_y/F_x gives the tangent of the angle, $\tan \phi$, so:

$$\phi = \tan^{-1} \left(\frac{13 \text{ lb}}{-4.0 \text{ lb}} \right) = 107^\circ \quad \text{Help: [S-10]}.$$

Next, the magnitude of the surface force is given by the square root of the sum of the squares of its components:

$$F_{\text{surface}} = \sqrt{(-4.0 \text{ lb})^2 + (13 \text{ lb})^2} = 13.6 \text{ lb} \approx 14 \text{ lb}.$$

This angle and magnitude checks against the approximate value drawn earlier in the one-body force diagram (Fig. 7).

4b. The Sled with Acceleration. Suppose we are asked to solve the sled problem of Sect. 4a when the sled is accelerating at, say, $a = 8.0 \text{ ft/s}^2 \hat{x}$ where the coordinate axes are as in Fig. 8. The mass of the sled is: $m = W/g = 16 \text{ lb}/(32 \text{ ft/s}^2) = 0.50 \text{ lb s}^2/\text{ft}$. Then the resultant force must be: $\vec{F}_R = m\vec{a} = 4.0 \text{ lb} \hat{x}$. Looking at Fig. 7 where the resultant force was zero, we must add the new \vec{F}_R to the surface force so that the result of adding all the forces, the new resultant, will be the new non-zero

\vec{F}_R . The result is shown in Fig. 9 where one can easily see that the sum of the forces points approximately in the \hat{x} direction. Breaking the forces into components gives Fig. 10: the surface force is now at an angle of 90° with a magnitude of 13lb. Mentally add the components and prove to yourself that the resultant is indeed equal to $m\vec{a}$.

4c. Block on Incline. A block weighing 98 N is at rest on a 37° incline. Our job is to determine the surface force on the block.

The forces acting on the block are two: the non-contact force of gravity and the contact force exerted on the block by the surface of the incline. The gravity force is $F_{\text{gravity}} = -98 \text{ N } \hat{y}$ and the resultant is zero (the block is “at rest”) so the force exerted on the block by the incline surface must be $F_{\text{surface}} = +98 \text{ N } \hat{y}$. This is shown in Fig. 11.

5. Connected Bodies

5a. Introduction. A type of problem frequently encountered which deserves special consideration involves two or more bodies that are coupled together by contact or by a rope or by a pole. Such bodies are constrained to move together and will have equal magnitudes of acceleration. If the connection is a rope, we can often neglect the weight of the rope since that force is small compared to the forces exerted at the ends of the rope. Now the forces acting on the ends of the rope are in opposite directions so their (vector) sum is just the difference of their magnitudes. By Newton’s second law that difference is just the rope’s mass times its acceleration. If we consider the rope’s mass to be too small to be important, then the rope will always have equal magnitudes of force on its two ends. That is what we almost always assume in determining approximate solutions.

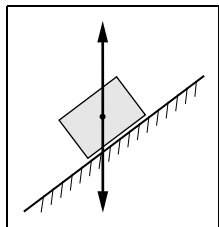

Figure 11. A block on an inclined plane.

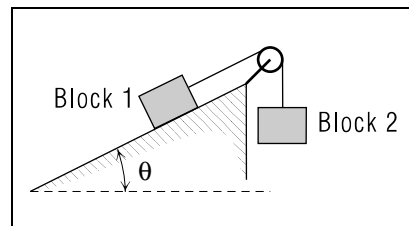

Figure 12. Two blocks connected by a string over a pulley.

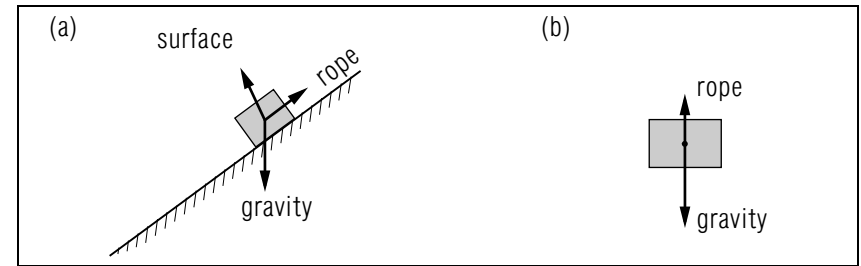

Figure 13. The forces for Fig. 12: (a) Block 1; (b) Block 2.

5b. Connected Blocks; One on Incline, One Hanging. Consider the system shown in Fig. 12. A block weighing 16lb is on a 37° incline and is attached to an inextensible massless rope which passes over a frictionless pulley to a second block that weighs 20lb. The hanging block is accelerating downward at 8 ft/s^2 . Our problem is to determine the surface force acting on the block that is on the incline.

Since the rope is massless, it will have equal forces on its two ends *Help: [S-2]*. This means we can solve for the rope force on the hanging block and that will be the rope force on the incline block. We draw one-body force diagrams for each block separately and these are shown in Fig. 13, where the force exerted by each end of the rope is labeled “rope”.

From the one-body force diagram for the hanging block we get that the resultant force ($\vec{F}_R = m\vec{a}$) is 5lb downward and the gravity force is 20lb (given) downward. Then the rope force must be 15lb upward. Check that the sum of the two quoted forces on the block is indeed equal to the required resultant force on the block.

Since the incline block is accelerating up the incline, we take our coordinate axes along the incline, as shown in Fig. 14. We break the

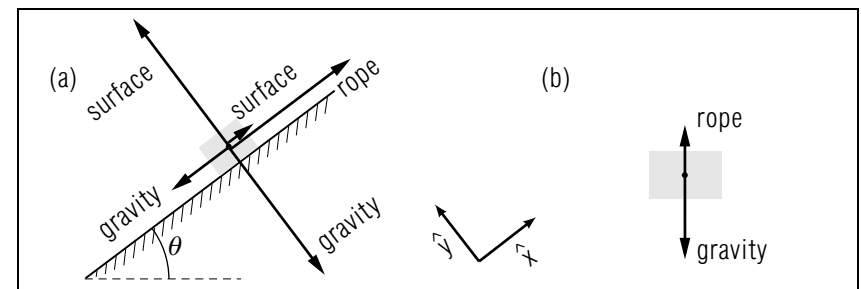

Figure 14. The force components for Fig. 13.

gravity force up into components along the axes shown and we get for the forces on the incline block:

$$\begin{aligned} F_{\text{gravity},x} &= W \sin 37^\circ = -9.6 \text{ lb} \\ F_{\text{gravity},y} &= W \cos 37^\circ = -12.8 \text{ lb} \\ F_{\text{rope},x} &= 15 \text{ lb} \\ F_{\text{rope},y} &= 0 \\ F_{R,x} &= ma_x = 4.0 \text{ lb} \\ F_{R,y} &= ma_y = 0 \end{aligned}$$

Now gravity plus rope plus surface must equal resultant so:

$$\begin{aligned} F_{\text{surface},x} &= -1.4 \text{ lb} \\ F_{\text{surface},y} &= 12.8 \text{ lb} \end{aligned}$$

Then the surface force on the incline block is 13 lb at an angle of 96° from the positive x -axis. *Help: [S-3]*

Acknowledgments

Preparation of this module was supported in part by the National Science Foundation, Division of Science Education Development and Research, through Grant #SED 74-20088 to Michigan State University.

PROBLEM SUPPLEMENT

Note: Problems 5 and 6 also occur in this module's *Model Exam*.

Important Note: Make each problem have these three separate parts:

- draw a one-body diagram with the forces "as given";
- draw a diagram similar to the one in part (a), but with the forces now represented only by their components, where one axis is along the direction of acceleration and the axes are labeled;
- write Newton's-second-law equations for the force components and solve for the components of the unknown force. Convert the answer components to magnitude and angle-to-the-acceleration direction.

- A 5.0 kg block is accelerating up a 37° incline at 3.0 m/s^2 by an applied force \vec{P} of 50.0 N as shown in the sketch. Note that \vec{P} is at an angle of 74° to the horizontal. Determine the surface force exerted on the block by the incline.

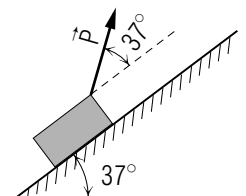

- A 32 pound child rides on a 16 pound sled. The child and sled are pushed across a horizontal surface by a force \vec{P} of 50.0 lb applied to the child as shown in the sketch. The acceleration is 2.0 ft/s^2 . Determine the force of the ground on the sled.

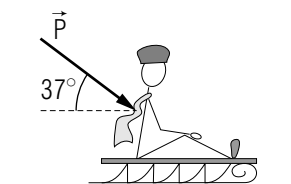

- A bob with a mass of 1.0 kg is suspended by a rope from the ceiling of a monorail car. As the car accelerates at 3.6 m/s^2 it is observed that the rope makes some angle θ measured clockwise from the downward vertical as shown in the sketch. Determine the (vector) surface force of the rope on the bob.

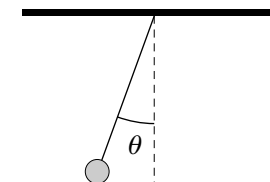

4. A 160 pound skier is pulled up a 23° slope by a rope tow as shown in the figure. The tension in the rope is 1.0×10^2 pounds. The skier's acceleration is 5.0 ft/s^2 . Determine the force of the slope on the skier.

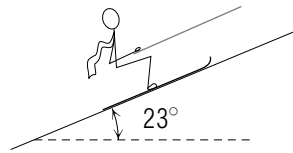

5. An airplane climbs upward in a direction 53° above the horizontal as shown in the figure. At the particular instant illustrated, the acceleration of the plane is 24 ft/sec^2 and is parallel to the direction of the velocity. Determine the (surface) force of the plane on the 160 pound pilot.

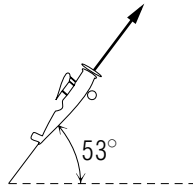

6. A 16 ton truck has a deceleration of 8.0 ft/s^2 as it coasts up a flat 14.5° grade. Determine the force of the road on the truck.

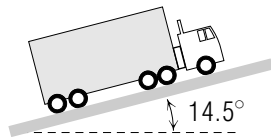

Brief Answers:

1a.

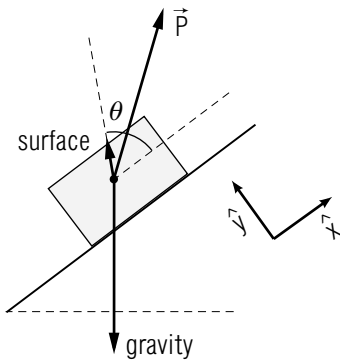

- 1c. $F_{\text{surface}} = 1.0 \times 10^1 \text{ N}$; $\theta_{\text{surface}} = 63^\circ$ Help: [S-4]

2a.

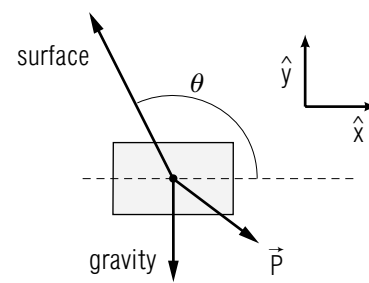

- 2c. $F_{\text{surface}} = 86 \text{ lb}$; $\theta_{\text{surface}} = 115^\circ$ Help: [S-5]

3a.

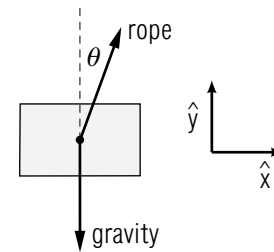

- 3c. $F_{\text{surface}} = 1.0 \times 10^1 \text{ N}$; $\theta_{\text{surface}} = (2.0 \times 10^2)^\circ$ Help: [S-6]

4a.

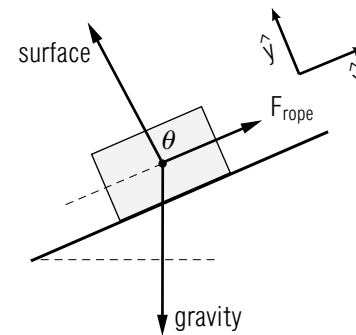

- 4c. $F_{\text{surface}} = 148 \text{ lb}$; $\theta_{\text{surface}} = 95^\circ$ Help: [S-7]

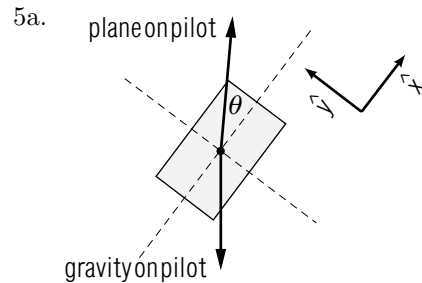

5c. $F_{\text{surface}} = 266 \text{ lb}$; $\theta_{\text{surface}} = 21^\circ$ Help: [S-8]

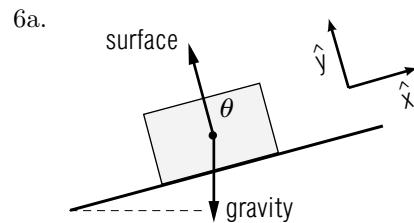

6c. $F_{\text{surface}} = 16 \text{ tons}$; $\theta_{\text{surface}} = (9.0 \times 10^1)^\circ$ Help: [S-9]

SPECIAL ASSISTANCE SUPPLEMENT

S-1 (from TX-4a)

If you have trouble with sine, cosine, and/or tangent functions, study the trigonometry section in “Math Review,” MISN-0-401 or study the relevant section in any high school trigonometry book.

S-2 (from TX-5b)

A rope can be treated just like any other object. If it has mass, then the difference between the magnitudes of the forces at its two ends is just (ma) for the rope. If the mass of the rope is negligible, then the difference between the magnitudes of the forces at its two ends is negligible.

S-3 (from TX-5b)

$$F_{\text{surface}} = \sqrt{(1.4 \text{ lb})^2 + (12.8 \text{ lb})^2} = 13 \text{ lb}$$

$\phi_{\text{surface}} = \tan^{-1} \left(\frac{12.8 \text{ lb}}{-1.4 \text{ lb}} \right) = -84^\circ$ or 96° (all arctangents have a 2-quadrant ambiguity: use other information to deduce which is the right answer).

S-4 (from PS-Problem 1)

$$F_{\text{gravity},x} = -29.49 \text{ N}; F_{\text{gravity},y} = -39.1 \text{ N}$$

$$F_{P,x} = 39.93 \text{ N}; F_{P,y} = 30.09 \text{ N}$$

$$F_{R,x} = ma_x = 15 \text{ N}; F_{R,y} = ma_y = 0$$

S-5 (from PS-Problem 2)

$$F_{\text{gravity},x} = 0; F_{\text{gravity},y} = -48 \text{ lb}$$

$$F_{P,x} = 4.0 \times 10^1 \text{ lb}; F_{P,y} = -3.0 \times 10^1 \text{ lb}$$

$$F_{R,x} = ma_x = 3.0 \text{ lb}; F_{R,y} = ma_y = 0$$

S-6 (from PS-Problem 3)

$$F_{\text{gravity},x} = 0; F_{\text{gravity},y} = -9.8 \text{ N}$$

$$F_{R,x} = ma_x = 3.6 \text{ N}; F_{R,y} = ma_y = 0$$

Also, note how the angle θ is defined in this problem.

S-7 (from PS-Problem 4)

$$F_{\text{gravity},x} = -62.5 \text{ lb}; F_{\text{gravity},y} = -147.3 \text{ lb}$$

$$F_{\text{rope},x} = 100 \text{ lb}; F_{\text{rope},y} = 0$$

$$F_{R,x} = m a_x = 25 \text{ lb}; F_{R,y} = m a_y = 0$$

S-8 (from PS-Problem 5)

$$F_{\text{gravity},x} = -127.8 \text{ lb}; F_{\text{gravity},y} = -96.3 \text{ lb}$$

$$F_{R,x} = m a_x = 120 \text{ lb}; F_{R,y} = m a_y = 0$$

S-9 (from PS-Problem 5)

If you have worked your way through all of the text in the module and have worked all of the previous problems in the Problem Supplement and still have trouble with this one, go back to the text of this module and review all parts of it. Then review your worked-out solutions to all of the prior problems. After doing those two things in their entirety, attempt this one again.

S-10 (from TX-4a)

If you got -73° then you have run into the “ambiguous quadrant” problem and you must do further work. Calculators generally give the arctangent of a positive number as being between 0° and 90° , in the first quadrant, although the actual angle may be in either the first or the third quadrant, and they give the arctangent of a negative number as being between 0° and -90° , in the fourth quadrant, although the actual angle may be in either the second or the fourth quadrant. To resolve either of these “quadrant ambiguities,” you must also examine the signs of the x - and y -coordinates of a point at the angle in question.

MODEL EXAM

Important Note: Make each problem have these three separate parts:

- draw a one-body diagram with the forces “as given”;
- draw a diagram similar to the one in part (a), but with the forces now represented only by their components, where one axis is along the direction of acceleration and the axes are labeled;
- write Newton’s-second-law equations for the force components and solve for the components of the unknown force. Convert the answer components to magnitude and angle-to-the-acceleration direction.

- An airplane climbs upward in a direction 53° above the horizontal as shown in the figure. At the particular instant illustrated, the acceleration of the plane is 24 ft/sec^2 and is parallel to the direction of the velocity. Determine the (surface) force of the plane on the 160 pound pilot.

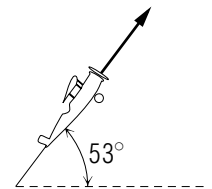

- A 16 ton truck has a deceleration of 8.0 ft/s^2 as it coasts up a flat 14.5° grade. Determine the force of the road on the truck.

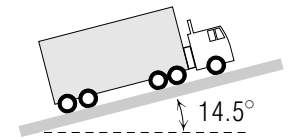

Brief Answers:

- See this module’s *Problem Supplement*, problem 5.
- See this module’s *Problem Supplement*, problem 6.

